



MICRON INDUSTRIES CORPORATION

**Catalog:
MIPS-07A
Switch Mode
Power Supplies**

**Effective Date:
March 1, 2007**

**Supersedes: MIPS-06B
November 1, 2006**

MICRON INDUSTRIES CATALOG MIPS-07A

Switch Mode Power Supplies

Table of Contents

| | |
|---|----|
| Quick-Select Guide <i>DI</i> Nergy and ImperviPOWER 67 | 3 |
| MD60 Series | 4 |
| MD120 Series | 6 |
| MD240 Series | 8 |
| MD480 Series | 10 |
| Operational and Mounting Requirements | 12 |
| MD-PSRM (Redundancy) Module | 14 |
| DC SagUPS | 16 |
| ImperviPOWER 67 Series | 21 |
| IP Definitions | 22 |

Micron DIergy™ Power Supply Selection Guide



| Model | Output Power (Watts) | Output Voltage (VDC) | Voltage Adj. Range | Output Current (A) | Peak Current (A) | Input Voltage (VAC) | Size WxDxH(mm) |
|-----------------------------------|-------------------------|----------------------|--------------------|--------------------|------------------|---------------------|----------------|
| MD60-24-1 | 60 | 24 | 22 -- 28 | 2.5 | 3.0 | 85-264 | 50x105x124 |
| MD60-12-1 | 54 | 12 | 10 -- 16 | 4.5 | 5.4 | 85-264 | 50x105x124 |
| MD60-48-1 | 60 | 48 | 46 -- 52 | 1.3 | 1.5 | 85-264 | 50x105x124 |
| MD120-24-1 | 120 | 24 | 22 -- 28 | 5.0 | 6.0 | 85-264 | 65x105x124 |
| MD120-12-1 | 96 | 12 | 10 -- 16 | 8.0 | 9.6 | 85-264 | 65x105x124 |
| MD120-48-1 | 120 | 48 | 46 -- 52 | 2.5 | 3.0 | 85-264 | 65x105x124 |
| MD240-24-1 | 240 | 24 | 22 -- 28 | 10.0 | 12.0 | 85-264 | 87x124x130 |
| MD240-12-1 | 180 | 12 | 11 -- 14 | 15.0 | 18.0 | 85-264 | 87x124x130 |
| MD240-48-1 | 240 | 48 | 46 -- 52 | 5.0 | 6.0 | 85-264 | 87x124x130 |
| MD480-24-1 | 480 | 24 | 22 -- 28 | 20.0 | 24.0 | 85-264 | 156x126x130 |
| MD480-36-1 | 480 | 36 | 34 -- 40 | 13.0 | 16.0 | 85-264 | 156x126x130 |
| MD480-48-1 | 480 | 48 | 46 -- 52 | 10.0 | 12.0 | 85-264 | 156x126x130 |
| MD-PSRM AVL 2007 | REDUNDANCY DIODE MODULE | | | | | | 50x105x124 |
| MD-VSB240-24-1 (AVL 2007) | 240 -- | 24 +/-10% | N/A | 10.0 | N/A | 24VDC +/- 5% | 76x116x130 |
| MD-LAB24 BATTERY (AVL 2007) | N/A | 24 | N/A | 2.6 AH/20Hr | N/A | N/A | 119x116x100 |

Micron ImperviPOWER 67™ Power Supply Selection Guide

| Model | Output Power (Watts) | Output Voltage (VDC) | Efficiency Rating | Temperature Rating | Input Voltage (VAC) | Size WxDxH(mm) |
|--------------|----------------------|----------------------|-------------------|--------------------|---------------------|----------------|
| MIP67-50-24 | 50 | 24 | ≥88% | -40C to +50C | 90-264 | 166x85x35 |
| MIP67-100-24 | 100 | 24 | ≥88% | -40C to +50C | 90-264 | 166x85x35 |

ALL UNITS HAVE AN ISOLATION RATING OF 3.3KVAC

MD60 Series 60W DINergy™ Power Supply

Features

- ✧ Compact size, high efficiency and DIN Rail mounting
- ✧ 100-240VAC wide-range auto-selection input
- ✧ Overcurrent, shortcircuit, and overvoltage protection
- ✧ DC OK LED status indicator
- ✧ Parallel operation capable
- ✧ Power boost available for large load start demand
- ✧ Safety meets UL508, UL60950 and IEC60950
- ✧ CE EN61000-3-2 compliant active PFC filtering
- ✧ EMI meets FCC15 B, EN55022 B and CISPR22 B
- ✧ High reliability, MTBF>200,000 hrs
- ✧ Operating temperature: -10°C to 70°C
- ✧ 5 year warranty



Micron DINergy™ units are suitable for process control systems, mechanical equipment, transport equipment, vending service equipment, building automation, and electronic/electrical instrumentation.

Specifications

| Model | MD60-12-1 | MD60-24-1 | MD60-48-1 |
|------------------------------|------------------------------|------------|-------------|
| Input Voltage | Rated 100-240VAC | | |
| | Range 85-264VAC | | |
| Input Current | 0.7A/240VAC, 1.3A/100VAC | | |
| Frequency | 50-60Hz, ±6% | | |
| Inrush Current | Typ.<25A | | |
| Earth Leakage Current | <3.5mA | | |
| Start-up Time | <1S | | |
| Rated Output Voltage/Current | 12VDC/4.5A | 24VDC/2.5A | 48VDC/1.25A |
| Output Set Point | 12.5±0.5% | 24.5±0.5% | 48.5±0.5% |
| Output Voltage Regulation | 10-16VDC | 22-28VDC | 46-52VDC |
| Rated Output Current | 4.5-3.8A | 2.5-2.1A | 1.25-1.15A |
| Min. Output Current | 0A | 0A | 0A |
| Output Peak Current | 120% of rated output current | | |
| Efficiency | 86%/230V | 86%/230V | 87%/230V |
| Ripple & Noise | <=100Mv | | |

| | | | |
|-----------------------------|---|------|------|
| Load Regulation | 1% | | |
| Voltage Regulation | 0.5% | | |
| Temperature Coefficient | 0.02%/°C | | |
| Hold-up Time | ≥20mS | | |
| Transient Overshoot | Load is changed from 50% to 100% step by step at a rate of 0.2A/μS, overshoot<500mV | | |
| Reverse Voltage Immunity | <16V | <35V | <63V |
| Safety | UL60950, UL508, EN60950 | | |
| EMC | FCC 15B, EN55022 B, EN61000-3-2, IEC61000-4-2,3, 4, 5, 6,8& 11 | | |
| Reliability | MIL HDBK 217F, 200,000hrs | | |
| Case Safety Standard | IEC60529, IP 20 | | |
| Pollution Standard | EN50178 Class 2 | | |
| Electrical Surge Protection | UL60950 Class I, PE is connected to ground | | |
| Outside Dimension | 1.97 (50.0) × 4.13 (105.0) × 4.88 (124.0) | | |
| Weight | 490g (0.89 lb) | | |

Performance

Output Characteristic Curve (I-V) (Output voltage 24VDC)

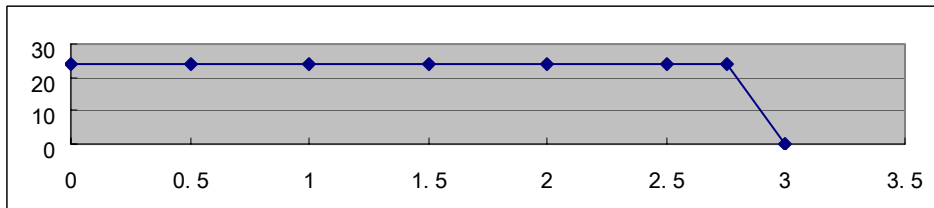

Temperature Corresponding Curve (T-P) (Output power 60W)

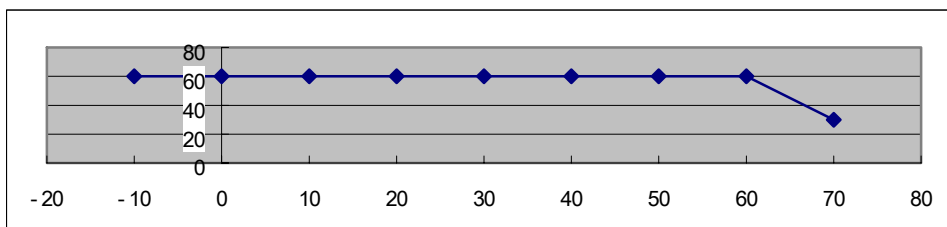

Protection

| Method | Threshold | Mode |
|-------------------------|--------------------------|--|
| Fuse | 3.15AT, 250V | Fast blow |
| Shortcircuit Protection | Automatic Recovery | Automatically recovers in normal operation after failure is removed. |
| Overcurrent Protection | 125-135% of rated output | |
| Overvoltage Protection | 110-130% of rated output | |

MD120 Series 120W DINergy™ Power Supply

- ✧ Compact size, high efficiency and DIN Rail mounting
- ✧ 100-240VAC wide-range auto-selection input
- ✧ Overcurrent, shortcircuit, and overvoltage protection
- ✧ DC OK LED Indicator w/remote indicator contact
- ✧ Adjustable DC output voltage
- ✧ Power boost for unusual start-up loading
- ✧ Parallel operation capable for power and redundancy
- ✧ Safety meets UL508, UL60950 and IEC60950
- ✧ CE EN61000-3-2 compliant active PFC filtering
- ✧ EMI meets FCC15 B, EN55022 B and CISPR22 B
- ✧ High reliability, MTBF>200,000 hrs
- ✧ Operating temperature: -10°C to 70°C
- ✧ 5 year warranty



Applications

Micron DINergy™ units are suitable for industrial and commercial process and control systems, office facilities, telecom equipment, mechanical equipment, transport equipment, service and building automation, and electronic and electrical instrumentation.

Specifications

| Model | MD120-12-1 | MD120-24-1 | MD120-48-1 |
|-----------------------------------|------------------------------|--------------------------|------------|
| Input Voltage | Rated 100-240VAC | | |
| | Range 85-264VAC | | |
| Input Current | 0.6A/240VAC, 1.3A/110VAC | 0.7A/240VAC, 1.6A/110VAC | |
| Frequency | 50-60Hz, ±6% | | |
| Inrush Current | Typ.<15A | | |
| Earth Leakage Current | <3.5mA | | |
| Start-up Time | <1S | | |
| PFC/Harmonics | >0.95/Meets EN61000-3-2 | | |
| Rated Output Voltage/Current | 12VDC/8A | 24VDC/5A | 48VDC/2.5A |
| Output Pre-regulation (Set Point) | 12.5±0.5% | 24.5±0.5% | 48.5±0.5% |
| Output Voltage Regulation | 10-16VDC | 22-28VDC | 46-52VDC |
| Rated Output Current | 8-6A | 5-4.3A | 2.5-2.3A |
| Min. Output Current | 0A | 0A | 0A |
| Output Peak Current | 120% of rated output current | | |
| Efficiency | 86%/230V | 88%/230V | 88%/230V |

| | | | |
|-----------------------------|---|------|------|
| Ripple & Noise | <=100mV | | |
| Load Regulation | 1% | | |
| Voltage Regulation | 0.5% | | |
| Temperature Coefficient | 0.02%/°C | | |
| Hold-up Time | >=20mS | | |
| Transient Overshoot | Load is changed from 50% to 100% step by step at a rate of 0.2A/μS, overshoot<500mV | | |
| Reverse Voltage Immunity | <16V | <35V | <63V |
| Safety | UL60950, UL508, EN60950 | | |
| EMC | FCC 15B, EN55022 B, EN61000-3-2, IEC61000-4-2,3, 4, 5, 6,8& 11 | | |
| Reliability | MIL HDBK 217F, 200,000hrs | | |
| Case Safety Standard | IEC60529, IP 20 | | |
| Pollution Standard | EN50178 Class 2 | | |
| Electrical Surge Protection | UL60950 Class I, PE is connected to ground | | |
| Outside Dimension | 2.56 (65.0)× 4.13 (105.0)× 4.89 (124.0) | | |
| Weight | 750g (1.37 lb) | | |

Performance

Output Characteristic Curve (I-V) (Output voltage 24VDC)

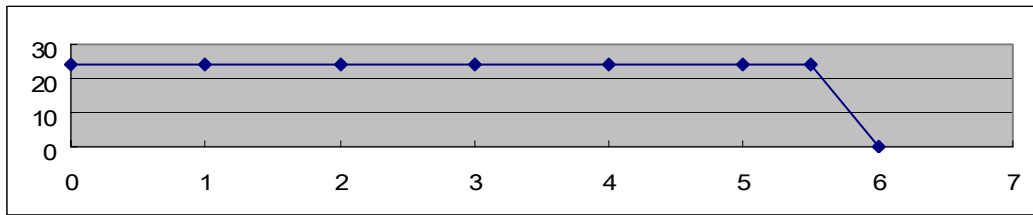

Temperature Corresponding Curve (T-P) (Output power 120W)

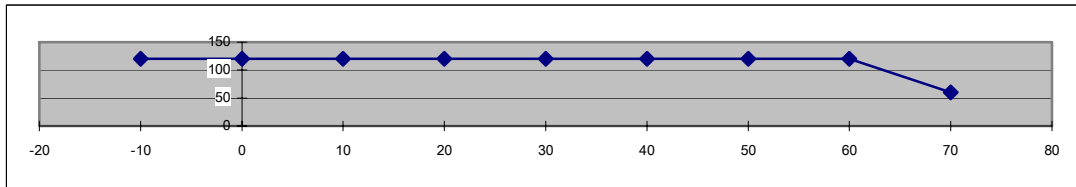

Protection

| Method | Threshold | Mode |
|-------------------------|--------------------------|--|
| Fuse | 3.15AT, 250V | Delay |
| Shortcircuit Protection | Automatic Recovery | Automatically recovers to normal operation after failure is removed. |
| Overcurrent Protection | 125-135% of rated output | |
| Overvoltage Protection | 110-130% of rated output | |
| Overheat Protection | 95°C | |

MD240 Series 240W DINergy™ Power Supply

Features

- ✧ 100-240VAC wide-range autoselect input
- ✧ Compact size, high efficiency and DIN Rail mounting
- ✧ Active PFC meets EN61000-3-2
- ✧ Overcurrent, shortcircuit, overvoltage and overheat protection
- ✧ DC OK LED and active output terminal for remote status check
- ✧ Power boost available for start up load demand
- ✧ Parallel operation (increase output power or redundant operation)
- ✧ UL508, UL60950 and IEC60950
- ✧ EMI meets FCC15 B, EN55022 B and CISPR22 B
- ✧ High reliability, MTBF>200,000 hrs
- ✧ 5 year warranty



Applications

Micron DINergy™ power supplies are suitable for process control systems, mechanical equipment, transport equipment, vending service equipment, building automation, and electronic/electrical instrumentation.

Specifications

| Model | MD240-12-1 | MD240-24-1 | MD240-48-1 |
|-----------------------------------|------------------------------|--------------------------|------------|
| Input Voltage | Rated 100-240VAC | | |
| | Range 85-264VAC | | |
| Input Current | 3A/100VAC, 1.3A/240VAC | 3.5A/100VAC, 1.6A/240VAC | |
| Frequency | 50-60Hz, ±6% | | |
| Inrush Current | Typ.<15A | | |
| Earth Leakage Current | <3.5mA | | |
| Start-up Time | <1S | | |
| PFC/Harmonics | >0.95/Meets EN61000-3-2 | | |
| Rated Output Voltage/Current | 12VDC/15A | 24VDC/10A | 48VDC/5A |
| Output Pre-regulation (Set Point) | 12.5±0.5% | 24.5±0.5% | 48.5±0.5% |
| Output Voltage Regulation | 10-16VDC | 22-28VDC | 46-52VDC |
| Rated Output Current | 15-11.3A | 10-8.6A | 5-4.6A |
| Min. Output Current | 0A | 0A | 0A |
| Output Peak Current | 120% of rated output current | | |
| Efficiency | 86%/230V | 88%/230V | 88%/230V |
| Ripple & Noise | ≤100mV | | |

| | | | |
|-----------------------------|---|------|------|
| Load Regulation | 1% | | |
| Voltage Regulation | 0.5% | | |
| Temperature Coefficient | 0.02%/°C | | |
| Hold-up Time | ≥20mS | | |
| Transient Overshoot | Load is changed from 50% to 100% step by step at a rate of 0.2A/μS, overshoot<500mV | | |
| Reverse Voltage Immunity | <16V | <35V | <63V |
| Safety | UL60950, UL508, EN60950 | | |
| EMC | FCC 15B, EN55022 B, EN61000-3-2, IEC61000-4-2,3, 4, 5, 6,8& 11 | | |
| Reliability | MIL HDBK 217F, 200,000hrs | | |
| Case Safety Standard | IEC60529, IP 20 | | |
| Pollution Standard | EN50178 Class 2 | | |
| Electrical Surge Protection | UL60950 Class I, PE is connected to ground | | |
| Outside Dimension | 3.43 (87.0) × 5.13 (130.0) × 4.88 (124.0) | | |
| Weight | 1,300g (2.37 lb) | | |

Performance

Output Characteristic Curve (I-V) (Output voltage 24VDC)

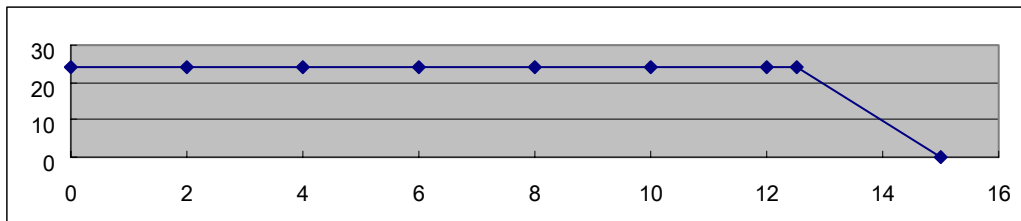

Temperature Corresponding Curve (T-P) (Output power 240W)

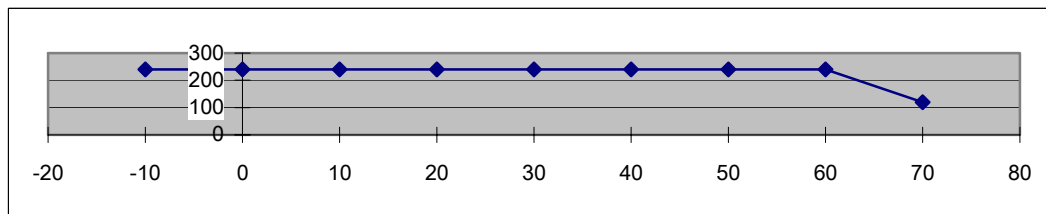

Protection

| Method | Threshold | Mode |
|-------------------------|--------------------------|--|
| Fuse | 6.3AT, 250V | Delay |
| Shortcircuit Protection | Automatic Recovery | Automatically recovers to normal operation after failure is removed. |
| Overcurrent Protection | 125-135% of rated output | |
| Overvoltage Protection | 110-130% of rated output | |
| Overheat Protection | 105°C | |

MD480 Series 480W DINergy™ Power Supply

Features

- ✧ 100-240VAC wide-range input
- ✧ Compact size, high efficiency and DIN Rail mounting
- ✧ Active PFC meets EN61000-3-2
- ✧ Overcurrent, shortcircuit, overvoltage, overheat protection
- ✧ DC OK LED and active output terminal for remote check
- ✧ Power boost provided for large start up demand
- ✧ Parallel for increased output power or redundant operation
- ✧ Safety meets UL508, UL60950 and IEC60950
- ✧ EMI meets FCC15 B, EN55022 B and CISPR22 B
- ✧ High reliability, MTBF>200,000 hrs
- ✧ 5 year limited warranty



Applications

Micron DINergy™ power supplies are suitable for process control systems, mechanical equipment, transport equipment, vending service equipment, building automation, and electronic/electrical instrumentation.

Specifications

| Model | MD480-24-1 | MD480-36-1 | MD480-48-1 |
|-----------------------------------|------------------------------|-------------|------------|
| Input Voltage | Rated 100-240VAC | | |
| | Range 85-264VAC | | |
| Input Current | 6.3A/100VAC, 2.6A/240VAC | | |
| Frequency | 50-60Hz, ±6% | | |
| Inrush Current | Typ.<30A | | |
| Earth Leakage Current | <3.5mA | | |
| Start-up Time | <1S | | |
| PFC/Harmonics | >0.95/Meets EN61000-3-2 | | |
| Rated Output Voltage/Current | 24VDC/20A | 36VDC/13.3A | 48VDC/10A |
| Output Pre-regulation (Set Point) | 24.5±0.5% | 36.5±0.5% | 48.5±0.5% |
| Output Voltage Regulation | 22-28VDC | 34-40VDC | 46-52VDC |
| Rated Output Current | 20-17.1A | 13.3-12A | 10-9.2A |
| Min. Output Current | 0A | 0A | 0A |
| Output Peak Current | 125% of rated output current | | |
| Efficiency | 90.4%/230V | 90.5%/230V | 90.7%/230V |

| | | | |
|-----------------------------|---|------|------|
| Ripple & Noise | <=100mV | | |
| Load Regulation | 1% | | |
| Voltage Regulation | 0.5% | | |
| Temperature Coefficient | 0.02%/°C | | |
| Hold-up Time | >=20mS | | |
| Transient Overshoot | Load is changed from 50% to 100% step by step at a rate of 0.2A/μS, overshoot<500mV | | |
| Reverse Voltage Immunity | <35V | <63V | <63V |
| Safety | UL60950, UL508, EN60950 | | |
| EMC | FCC 15B, EN55022 B, EN61000-3-2, IEC61000-4-2,3, 4, 5, 6,8& 11 | | |
| Reliability | MIL HDBK 217F, 200,000hrs | | |
| Case Safety Standard | IEC60529, IP 20 | | |
| Pollution Standard | EN50178 Class 2 | | |
| Electrical Surge Protection | UL60950 Class I, PE is connected to ground | | |
| Outside Dimension | 6.14 (156.0) × 4.96 (126.0) × 5.12 (130.0) | | |
| Weight | 2,250g (4.73 lb) | | |

Performance

Output Characteristic Curve (I-V) (Output voltage 24VDC)

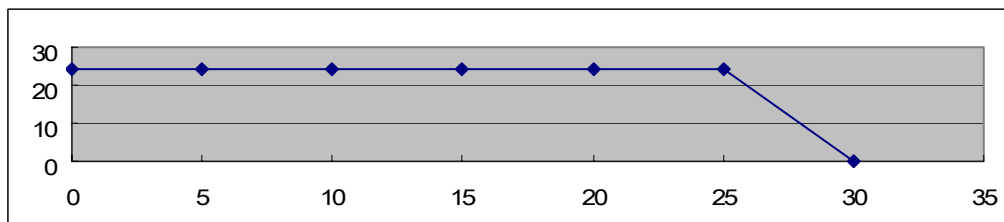

Temperature Corresponding Curve (T-P) (Output power 480W)

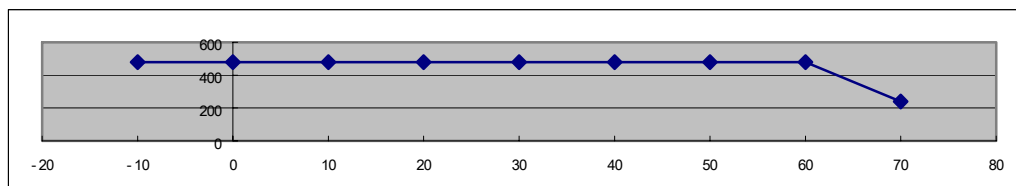

Protection

| Method | Threshold | Mode |
|-------------------------|--------------------------|--|
| Fuse | 12AT, 250V | Delay |
| Shortcircuit Protection | Automatic Recovery | Automatically recovers after cause is removed. |
| Overcurrent Protection | 125-135% of rated output | |
| Overvoltage Protection | 110-130% of rated output | |
| Overheat Protection | 90°C±5°C | |

Operational and Mounting Requirements (All DINergy Units)

Parallel Operation to Increase Output Power

To increase output power, the outputs of the same polarity of two identical units can be paralleled using load connection wires of the same gauge and length.

Parallel Operation for Redundancy Application

To increase reliability of the system, two units of the same model can be used for redundancy operation. In normal state, the units each provides 50% of load current. When failure occurs on the circuit of the unit 1, the unit 2 is able to immediately and automatically replace unit 1 to continue the operation and provides 100% load current. The same result applies when the failure occurs on the circuit of unit 2. In this application, a fuse or decoupling diode is added at the positive outputs of the two units.

Operating Environment

Operating temperature: -10 to 70°C

Operating humidity: 5% to 90%RH, non-condensing

Storage and shipping temperature: -40 to 85 °C

Vibration: meet IEC 68-2-6

Shock: meet IEC 68-2-27

Cooling Method

Air convection cooling is employed. From the ambient temperature of -10°C to 60°C, full rated output power available . From 60°C to 70°C, the unit is derated at 6W/1°C, and to half load when at 70°C.

Panel

Input Terminal

- 1). Connect L to AC line or DC positive pole.
- 2). Connect N to AC neutral or DC negative pole.
- 3).  connect to ground.



Output Terminal

- 1). DC OK output signal terminal
(not available on 60 watt unit)
- 2). “+”, DC positive output terminal (two)
- 3). “-”, DC negative output terminal (two)



DC OK Indicator

- 1). The indicator lights up indicating the unit operates normally.
- 2). The indicator flashes indicating output voltage is over normal value or load shortcircuit, overload or overheat occurs on the secondary.
- 3). The indicator turns off indicating power failure or there is no AC input.

Active DC OK Output Signal Terminal

For users' convenience to remotely inspect the operating status of the unit, an active DC OK output signal terminal is provided inside the unit. Users can connect an indicator or the equivalent (40mA) between the terminal and output negative terminal for remote inspection. The indicator is similar as the DC OK indicator.

Output Voltage Adjustment Hole

By adjusting the potentiometer behind the panel hole with a small screwdriver while measuring the voltage across the positive terminal & negative terminal with a multimeter, the user can set the DC output voltage to a desired value.

Mounting Method

A TS35/7.5 or TS35/15 rail of certain length corresponding to the width of the unit is provided for convenient DIN rail mounting. The required mounting clearance space for left/right is 25mm each, and above/below is 70mm each.

MD-PSRM DINergy™ Power Supply Diode Module for Redundant Configuration

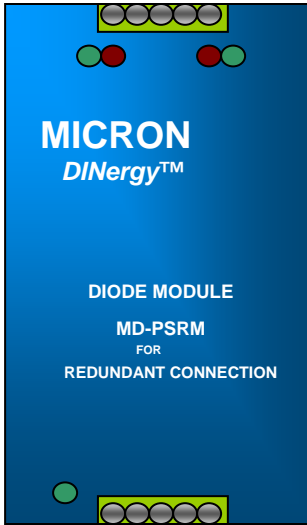

Micron DINergy™ power supplies can be connected in parallel to provide redundant rated output power and voltage for fail-safe requirements. To achieve this, a user may connect two identical Micron units with equal output voltage settings, connecting a Micron diode module MD-PSRM to prevent back-feeding or looping in the event of failure of one of the units. The MD-PSRM consists of a diode array enclosed within a DIN rail mounting metal case, and is equal in size to a 60w DINergy power supply.

- ✧ Common appearance with DINergy™ power supply family
- ✧ Compact size and DIN Rail mounting

| | |
|---------------------------|---|
| Outside Dimension in.(mm) | 1.97 (50.0) × 4.13 (105.0) × 4.88 (124.0) |
| Weight | 275g (0.50 lb) |

To increase reliability of system, use two power supplies of the same model for redundancy operation. Use load connection wires of the same gauge and length. Set the output voltages of all units to the same values. Connect decoupling diode module MD-PSRM to the positive outputs of the paralleled units. In normal state, each unit provides 50% of load current. When failure occurs on the circuit of the unit 1, unit 2 is able to immediately and automatically replace unit 1 to continue the operation at 100% rated current. The same will be true if the failure occurs on circuit of unit 2.

Mounting Method

A TS35/7.5 or TS35/15 rail of certain length corresponding to the width of the unit is provided for convenient DIN rail mounting.

MICRON MD-PSRM CONNECTION DIAGRAM/SCHEMATIC

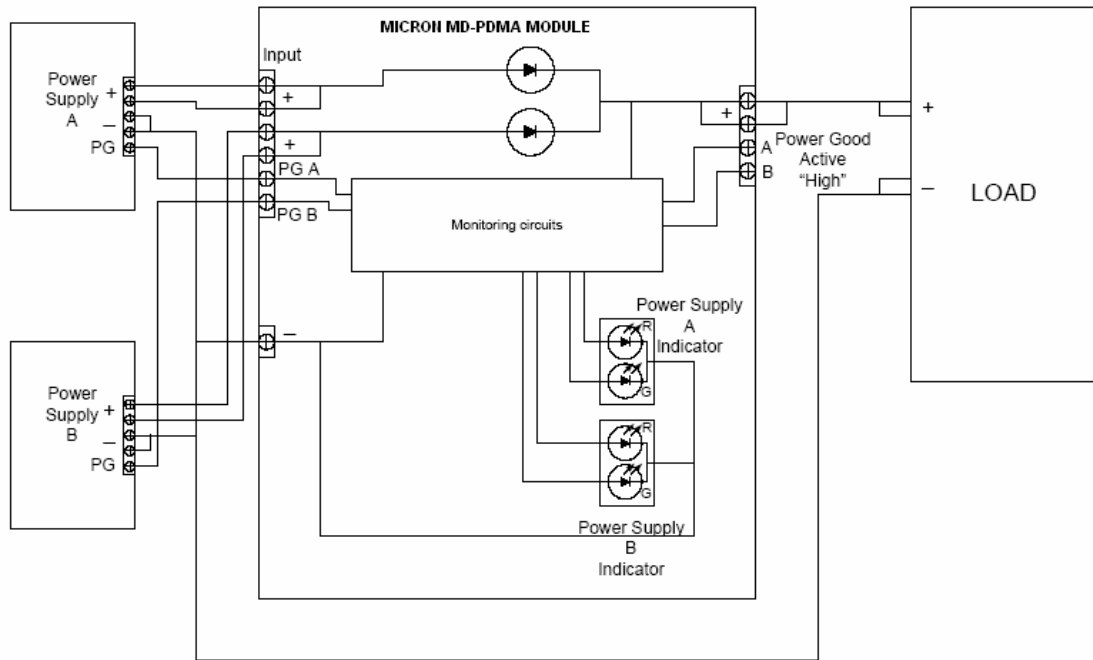



DIN Rail DC-Sag UPS with Backup Battery

“DINergy” Series

DIN Rail

DC-Sag-UPS Module

**24VDC, 10 Amp
External Battery Option**

KEY FEATURES

- No-Maintenance Sag Protection
 - Optional External Backup Battery Pack.
Up to 10 minutes
(extra Battery Packs available separately)
 - Industrial Design and Construction;
Compact Size with Rugged Metal Case
 - Standard DIN Mounting
 - 700 msec. Backup at 10A, (no Ext. Battery)
4 min. Backup at 10A (with Ext. Battery)
- No fans for high MBTF
 - ”DC OK” Signal
 - ”CHARGING” Indicator LED
 - Circuit and Damage Protection
 - Meets:
UL/C-UL, EN 50081-2, EN 61000-6-2

DESCRIPTION

DC Power is a critical energy to most automation solutions today. Loss of power can wreak havoc on data communication, product and process quality, and system productivity. Micron gives customers the ability to increase this 24Volt DC availability by the use of its DC SagUPS product. The DC-SagUPS (Sag Buffer plus Uninterruptible Power Supply) can help equipment ride through many nuisance sags and help provide orderly shutdown in a more sustained power loss. .

The DC SagUPS uniquely takes the guesswork out of power availability to DC control systems and equipment, especially where power issues are difficult to quantify. Featuring a unique two stage Sag-buffer plus optional Battery back-up function, customers can tailor their power availability needs from milliseconds to minutes depending on their environment, location, or equipment.

The DC SagUPS features a 24V buffer stage that protects against one of the most common forms of power quality problems: the sag. Using maintenance-free, ultra capacitors, the unit can provide up from 700ms to 10 seconds of hold-up (load dependent). For increased hold-up time, an integral

battery charger allows the user to add batteries for hold-up up from 4 - 10 minutes. Customers can purchase the unit for sag protection, and if longer run times are required, buy the optional DIN Rail mount battery packs.

The DCSagUPS is a compact, highly reliable solution to DC availability. The life expectancy of the product is extremely high when compared to its AC UPS competition due to its Industrial temperature range, zero fans, a lower component count, and the optional/replaceable batteries.

The DCSagUPS complements a broad range of Industrial DC Power Supplies to gives its customers the ultimate in DC power reliability.

MODEL SELECTION GUIDE

| DCSagUPS Model | Configuration | Rating | Battery |
|-----------------------|--------------------------------|------------------|------------------|
| MD-VSB240-24-1/LAB24 | DC-UPS (with External Battery) | 10 Amps / 2.6 AH | Sealed Lead Acid |
| MD-VSB240-24-1 | DC-UPS Module only | 10 Amps | N/A |
| MD-LAB24 | External Battery only | 10 Amps / 2.6 AH | Sealed Lead Acid |

SPECIFICATIONS

NOTE: Products are rated for industrial environments and are not to be used nor are warranted in aerospace, medical or lifesafety applications.

GENERAL (DC-UPS with External Battery)

| | |
|-------------------------|-------------------------|
| Operating Temperature | 0 to +75 C |
| Storage Temperature | -15 to +75 C |
| Relative Humidity (25C) | ≤ 95%RH, non-condensing |

| | |
|-------------------|--|
| Weight | 2.5 lbs (1.13 kg): DC-UPS 6.0 lbs (2.7 kg): Ext. Battery. |
| Vibration / Shock | 2.3g, 90min / 30g |
| Certifications | Meets: UL/C-UL(60950) EN 50081-2, EN 61000-6-2 |

ELECTRICAL

DC-UPS Module (1)

| | | | |
|---|--|----------------------|--|
| Rated DC Input | 24 VDC +/- 5%, 11 A (Internal usage: < 1 A) | DC Output Transition | < 0.8 ms, with < -10% DC output drop |
| Rated DC Output | 24 VDC +/- 10%, 10 A | DC Output Protection | Front Access Fuse, 12A |
| Charger Output (1) | 27.3 VDC, ≤ 0.5 A | Battery Status | “CHARGING” LED ”DC OK” Signal (open collector, 5 mA) |
| Charging Time (1) | 4 Hr. max. | Connections | See Mechanical Dwg. |
| Low Voltage Trip Points (falling / recovering) | 22.7 VDC / 22.8 VDC | MTBF | > 500,000 Hrs |
| Low Voltage Boost | ≥ 22.1 VDC | Warranty | (tbd) |
| Low Voltage Shutdown | ≤ 19.8 VDC Battery & ≤ 22.3 VDC DC Input | | |

External Battery Module (1)

| | | | |
|--------------|-----------------------|------------|---------------------|
| Battery Type | Sealed Lead Acid | Connectors | See Mechanical Dwg. |
| Rating | 24VDC, 2.6 AH / 20 Hr | Warranty | 2 Years |

(1) For Battery protection against damage, the external charger source connected to the Sealed Lead Acid Backup Battery module must only be the DC-UPS model MD-VSB240-24-1 charger.

OUTPUT TRANSITION (supply power to battery power; at 10 Amps load)

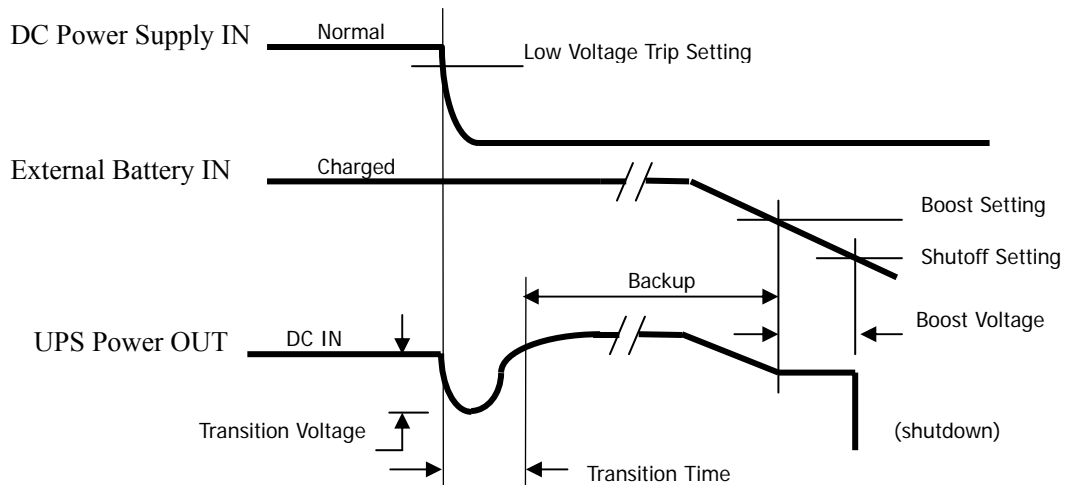

OUTPUT CURRENT HOLD TIME

| Output Load Current | No External Battery | With External Battery |
|---------------------|---------------------|-----------------------|
| 1 Amps | 10 sec | (tbd) |
| 5 Amps | 2 sec | 10 min |
| 10 Amps | 0.7 sec | 4 min |

BLOCK DIAGRAM

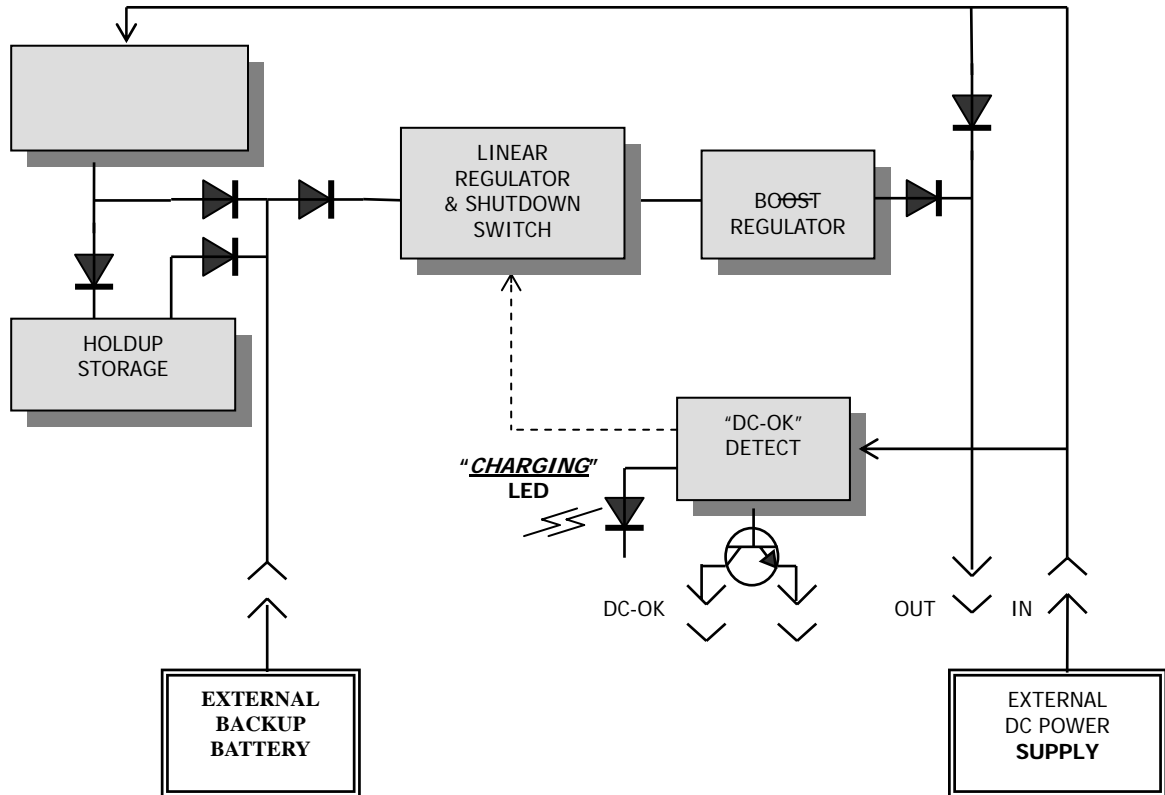

OPERATION

As shown in the diagram above, the 24 VDC Input power source feeds the internal Charger. The Charger charges the Holdup Storage capacitor and the (optional) External Backup Battery. When the DC Input voltage becomes low, the DC-UPS switches the DC Output to the Battery source. The Linear Regulator and Boost Regulator work together to convert the energy of the Holdup Storage and Backup Battery to a regulated Holdup output voltage.

- **NORMAL** – When the 24 VDC Input power source is normal and above the low voltage trip point, the DC Input voltage is routed to the DC Output terminals.

- **LOW VOLTAGE** – When the 24 VDC Input power source fails or a transient occurs below the “Boost” trip point, the DC-UPS switches to the Internal Storage or optional Backup Battery source. The Linear Regulator and Boost Regulator maintain the DC Output energy at the Boost Voltage.
- **SHUTDOWN** – When the Holdup Buffer storage capacitor or (optional) External Backup Battery fall below the “Automatic Shutdown” point, the DC-OK Detection circuit automatically shuts off the DC Output. This protects the Battery from persistent overload and possible damage.
- **RECOVERY** – If Input power source should recover, the Holdup circuit will resume normal operation and the Charger will resume charging the External Backup Battery.

BATTERY STATUS

| LED | DC OK Signal |
|---|---|
| ON – Normal DC Input, Backup source is charging | CONDUCTING (5ma) – DC Input is Normal. |
| OFF – Low Voltage DC Input, Backup source is not charging | OPEN (Bvce 36V) – DC Input is not Normal. |

MECHANICAL (not to scale)

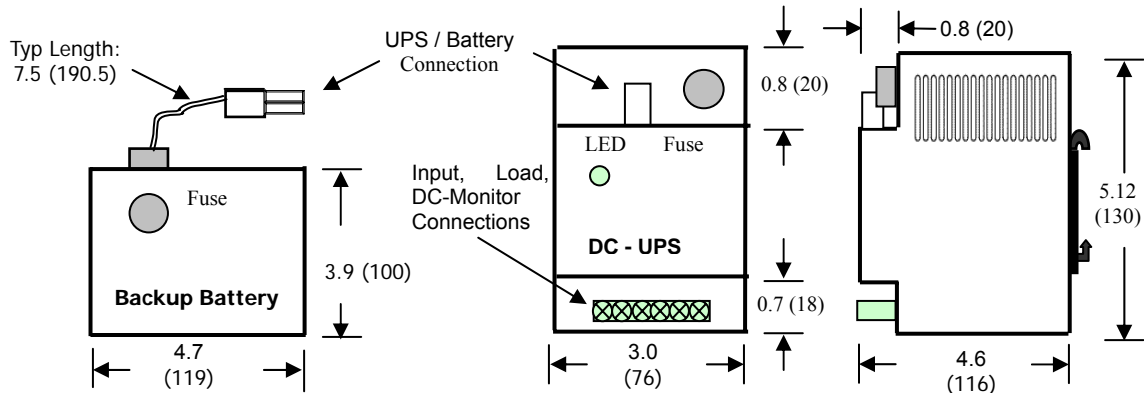

CONNECTIONS

| TERMINAL | DESCRIPTION |
|---------------------|--|
| IN 24V | 24 VDC External Power Input (+/-). |
| OUT 24V | 24 VDC Output Load (+/-). |
| DC-OK | Open Collector output signal (+/-). |
| UPS / Battery Cable | 24 VDC (+/-) between UPS and Battery only. |

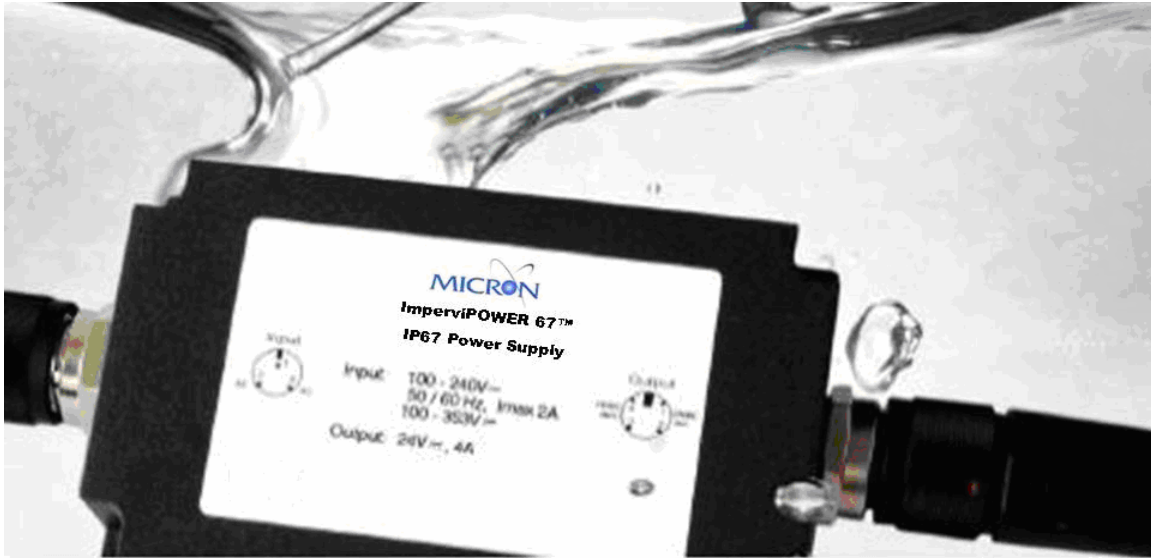

Power where you need it!
MICRON ImperviPOWER 67 Series
IP-67 Power Supplies



Wet environments? Not a problem with Micron's new ImperviPOWER® 67™ Series power supplies. Featuring a vacuum encapsulated construction with industrially hardened connectors, these IP-67 compliant products allow the placement of control power supplies at or near the point of utilization instead of being limited to a remote cabinet or separate enclosure.

Save time, money and wire management stress with the new ImperviPOWER 67 product line from Micron ... the industry leader in power delivery solutions.

TECHNICAL SPECIFICATIONS

| CATALOG NUMBER | POWER RATING | INPUT VAC | OUTPUT VDC | EFFICIENCY RATING | AMBIENT TEMP RATING | PHYSICAL DIMENSIONS INCHES (MM) |
|----------------|--------------|-----------|------------|-------------------|---------------------|---------------------------------|
| MIP67-50-24 | 50W | 90-264 | 24 | ≥88% | -40C TO +50C | 6.6 X 3.4 X 1.4 (166 X 85 X 35) |
| MIP67-100-24 | 100W | 90-264 | 24 | ≥88% | -40C TO +50C | 6.6 X 3.4 X 1.4 (166 X 85 X 35) |

ALL UNITS HAVE AN ISOLATION RATING OF 3.3KVAC

Unit complies with applicable standards including UL60950, EN60950, CSA 22.2, EN55011, EN6100-6, EN6000-6-2, -4-2, -4-3, -4-4, -4-5, -4-6, and -4-11

Connector interfaces are suitable for use with IP67 rated 7/8" straight/angled male/female connectors (Please contact Micron for specific details).

IP (Ingress Protection) Definitions

The following table defines the IP numbers.

Example: Protection level offered by an IP 67 rated protected product

6 = Totally protected from dust
7 = Protected from the effects of immersion between 15cm and 1m

▶ Protection against solid objects

First Number

- 0** No protection
- 1** Protected from solid foreign objects of 50 mm and greater (e.g., accidental touch by hands)
- 2** Protected from solid objects of 12 mm and greater (e.g., fingers)
- 3** Protected from solid objects more than 2.5 mm (e.g., tools and small wires)
- 4** Protected from solid objects more than 1 mm (e.g., small wires)
- 5** Protected from dust; limited entrance (no harmful deposit)
- 6** Totally protected from dust

▶ Protection against liquids

Second Number

- 0** No protection
- 1** Protected from vertically-falling drops of water (e.g., condensation)
- 2** Protected from direct sprays of water up to 15° from vertical
- 3** Protected from direct sprays of water up to 60° from vertical
- 4** Protected from water sprayed from all directions; limited entrance allowed
- 5** Protected from low pressure jets of water from all directions; limited entrance allowed
- 6** Protected from strong jets of water (e.g., for use on ship decks); limited entrance allowed
- 7** Protected from the effects of immersion between 15cm and 1m
- 8** Protected from extended periods of immersion under pressure

IP Numbers with Hermetically Sealed (HS) or Environmentally Protected (EP) Ratings

Rating Protection

| | |
|----------------|---|
| EP | Dust proof, not protected from moisture or water |
| IP65 | Dust proof, protected from splashes and low-pressure jets |
| IP66 | Dust proof, protected from strong water jets |
| IP67 | Dust proof, protected from temporary immersion in water 1 meter deep for 30 minutes |
| IP68 | Dust proof, protected from continuous immersion in water under more severe conditions than IP67 |
| IP66/68 | Dust proof, protected from strong water jets and/or constant immersion |



Micron Industries Corporation
777 North Church Road
Elmhurst, IL 60126
Phone: 800-664-4660
FAX: 630-516-1820
www.microntransformers.com