

# Stepper Motors







Products and specifications subject to change without notice.



Order/Technical Support - Tel: (800) 677-5311 / FAX: (800) 677-3865 / [www.crouzet-usa.com](http://www.crouzet-usa.com)

# Stepper motors selection guide

Gearboxes	Torque max (Nm)	0.5
	Gearbox type	81 021

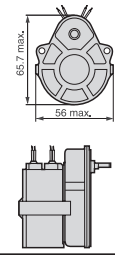
Direct motors				
Absorbed Power (w)	Holding torque (mN.m)		Number of steps	Motor type dimensions (mm)
	2 phases	4 phases		
5	20	15	24	▶ p.114 82 910 Ø 35 
5	25	20	48	▶ p.116 82 910 Ø 35 
7.5	70	57	48	▶ p.122 82 920 Ø 51 
10	180	155	48	▶ p.120 82 930 Ø 58 
12.5	300	240	48	▶ p.124 82 940 Ø 65 



▶ p.126 82 914 
▶ p.126 82 914 
▶ p.126 82 924 

### Selection of a geared motor









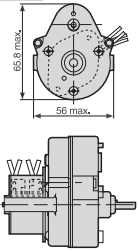
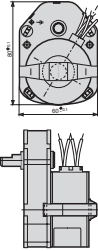
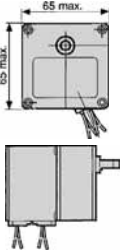

This choice is based upon the desired usable power at the gearbox output shaft

$$\text{Power (W)} = \frac{2\pi}{60} C \text{ (Nm)} \cdot n \text{ (Rpm)}$$

A geared motor must have usable power equal to or greater than the power required to rotate the load desired. It is selected by checking that the point corresponding to the required operating conditions (torque and speed output) is higher than the nominal torque versus speed curve of the geared motor. The required torque output of a geared motor must be within its maximum recommended torque for continuous duty.

Products and specifications subject to change without notice.

Order/Technical Support - Tel: (800) 677-5311 / FAX: (800) 677-3865 / www.crouzet-usa.com

2	3	5
81 033	81 023	81 037
		
▶ p.128 <b>82 919</b>	▶ p.132 <b>80 913</b>	▶ p.130 <b>80 917</b>
		
▶ p.128 <b>82 919</b>	▶ p.132 <b>80 913</b>	▶ p.130 <b>80 917</b>
		
▶ p.128 <b>82 929</b>	▶ p.132 <b>80 923</b>	▶ p.130 <b>80 927</b>
		
	▶ p.132 <b>80 933</b>	
		▶ p.134 <b>80 947</b>
		

Products and specifications subject to change without notice.

Order/Technical Support - Tel: (800) 677-5311 / FAX: (800) 677-3865 / [www.crouzet-usa.com](http://www.crouzet-usa.com)

# Direct drive stepper motors

→ 7.5° 5 Watts

- 48 steps/revolution (7.5°)
- Absorbed power : 5 W
- 2 or 4 phase versions available



## Specifications

Type	Part numbers	2 phase		2 phase		2 phase	
		82 910		82 910		82 910	
	Plastic bearing	<b>82 910 32D000002</b> ●	<b>82 910 32C000002</b> ●	<b>82 910 32B000002</b> ●			
	Sintered bronze bearing	<b>82 910 001</b>	<b>82 910 2C000002</b> ●	<b>82 910 2B000002</b> ●			
<b>General characteristics</b>							
Resistance per phase (Ω)		9	12.9	66			
Inductance per phase (mH)		12	15	68			
Current per phase (A)		0.52	0.44	0.19			
Holding torque (mN.m)		25	25	25			
Voltage at motor terminals (V)		4.7	5.6	12.7			
Absorbed power (W)		5	5	5			
Step angle (°)		7.5	7.5	7.5			
Positioning accuracy (mm)		5	5	5			
Inertia of rotor (gcm <sup>2</sup> )		4.9	4.9	4.9			
Max. detent torque (mN.m)		3	3	3			
Max. coil temperature (°C)		120	120	120			
Storage temperature (°C)		-40 → +80	-40 → +80	-40 → +80			
Thermal resistance of coil - ambient air (°C/W)		14	14	14			
Insulation resistance (at 500 Vcc) (MΩ) following NFC 51200 standard		> 10 <sup>3</sup>	> 10 <sup>3</sup>	> 10 <sup>3</sup>			
Insulation voltage (50 Hz, 1 minute) (V) following NFC 51200 standard		> 600	> 600	> 600			
Wires length (mm)		250	250	250			
Weight (g)		90	90	90			
Protection rating		IP 40	IP 40	IP40			

## Products adaptations, available on request

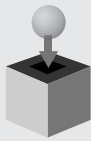

- Special output shafts
- Pinion on output shaft
- Special supply voltages
- Special lead lengths
- Special output bearings
- Customized electronics
- Special construction materials
- Special connectors

Products and specifications subject to change without notice.

Order/Technical Support - Tel: (800) 677-5311 / FAX: (800) 677-3865 / www.crouzet-usa.com

## Curves

Inertia of measuring chain : 1.5 g.cm<sup>2</sup>

a = constant voltage controller with R<sub>s</sub> (resistance in series) = 0

b = constant voltage controller with R<sub>s</sub> (resistance in series) = R motor

c = constant voltage controller with R<sub>s</sub> (resistance in series) = 2R motor

d = constant voltage controller with R<sub>s</sub> (resistance in series) = 3R motor

The measurements are made with full stepping, 2-phases energized.

2 phases

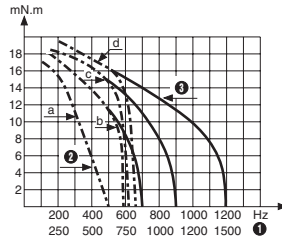

B RPM  
C Max. stopping-starting curves  
D Max. operating curves

Max. stopping-starting and operating curves at I constant (PBL 3717) for 2 (motor) phases 12.9 Ω

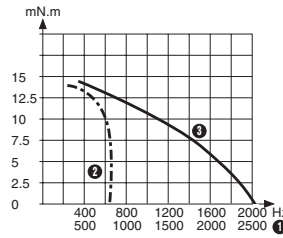

B RPM  
C Max. stopping-starting curves  
D Max. operating curves

Max. stopping-starting frequency curves as a function of the external inertia load at zero antagonistic torque

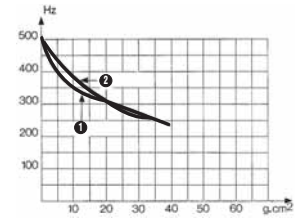

B 2 phases  
C 4 phases

## Dimensions

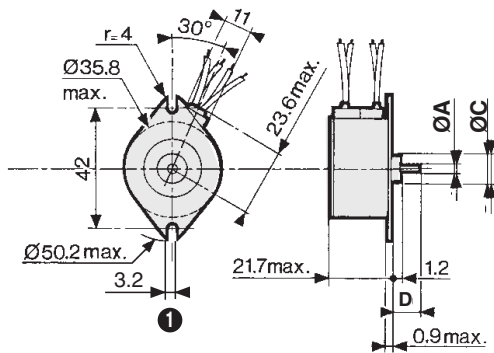

B 2 fixing holes Ø 3.2

Shaft Type	Ø shaft - A	Ø center - C	Length shaft - D
Type 1	2 <sup>-0.002</sup> <sub>-0.006</sub>	9 <sup>-0.010</sup> <sub>-0.060</sub>	9
Type 2	2 <sup>-0.002</sup> <sub>-0.006</sub>	10 <sup>-0.010</sup> <sub>-0.060</sub>	9
Type 3	3.17 <sup>0</sup> <sub>-0.006</sub>	9.52 <sup>-0.010</sup> <sub>-0.060</sub>	9

## Connections

2 phase

	1	2	3	4
1	-	+	-	+
2	-	+	+	-
3	+	-	+	-
4	+	-	-	+
5	-	+	-	+

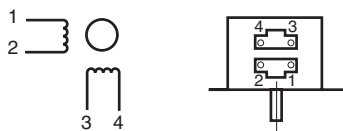

B Step  
Energization sequence for clockwise rotation (viewed shaft end)

Products and specifications subject to change without notice.

Order/Technical Support - Tel: (800) 677-5311 / FAX: (800) 677-3865 / www.crouzet-usa.com

# Direct drive stepper motors

→ 7.5° 5 Watts

- 48 steps/revolution (7.5°)
- Absorbed power : 5 W
- 2 or 4 phase versions available



## Specifications

	4 phase	4 phase	4 phase
Type	82 910 0	82 910 0	82 910 0
Electronic controller used	Unipolar	Unipolar	Unipolar
<b>Bearings</b>			
Sintered bronze	<b>82 910 4A000002</b>	<b>82 910 4B000002</b>	<b>82 910 4H000002</b>
Plastic	<b>82 910 34A000002</b>	<b>82 910 34B000002</b>	<b>82 910 34HC000002</b>
<b>General characteristics</b>			
Electronic controller used	Unipolar	Unipolar	Unipolar
Resistance per phase (Ω)	15.5	66	115
Inductance per phase (mH)	8	28	55
Current per phase (A)	0.4	0.19	0.14
Holding torque (mN.m)	20	20	20
Voltage at motor terminals (V)	6.2	12.7	17
Absorbed power (W)	5	5	5
Step angle (°)	7.5	7.5	7.5
Positioning accuracy (mm)	5	5	5
Inertia of rotor (gcm <sup>2</sup> )	4.9	4.9	4.9
Max. detent torque (mN.m)	3	3	3
Max. coil temperature (°C)	120	120	120
Storage temperature (°C)	-40 → +80	-40 → +80	-40 → +80
Thermal resistance of coil - ambient air (°C/W)	14	14	14
Insulation resistance (at 500 Vcc) (MΩ) following NFC 51200 standard	> 10 <sup>3</sup>	> 10 <sup>3</sup>	> 10 <sup>3</sup>
Insulation voltage (50 Hz, 1 minute) (V) following NFC 51200 standard	> 600	> 600	> 600>
Wires length (mm)	250	250	250
Weight (g)	90	90	90
Protection rating	IP 40	IP 40	IP40

## Products adaptations, available on request

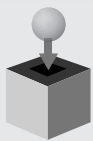

- Special output shafts
- Pinion on output shaft
- Special supply voltages
- Special lead lengths
- Special output bearings
- Customized electronics
- Special construction materials
- Special connectors

Products and specifications subject to change without notice.

Order/Technical Support - Tel: (800) 677-5311 / FAX: (800) 677-3865 / www.crouzet-usa.com

## Curves

Inertia of measuring chain : 1.5 g.cm<sup>2</sup>

a = constant voltage controller with R<sub>s</sub> (resistance in series) = 0

b = constant voltage controller with R<sub>s</sub> (resistance in series) = R motor

c = constant voltage controller with R<sub>s</sub> (resistance in series) = 2R motor

d = constant voltage controller with R<sub>s</sub> (resistance in series) = 3R motor

The measurements are made with full stepping, 2-phases energized.

4 phases

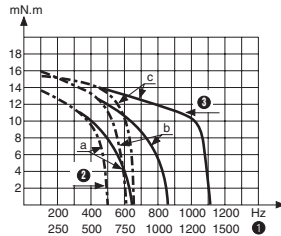

B RPM  
C Max. stopping-starting curves  
D Max. operating curves

Max. stopping-starting frequency curves as a function of the external inertia load at zero antagonistic torque

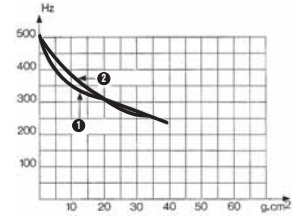

B 2 phases  
C 4 phases

## Dimensions

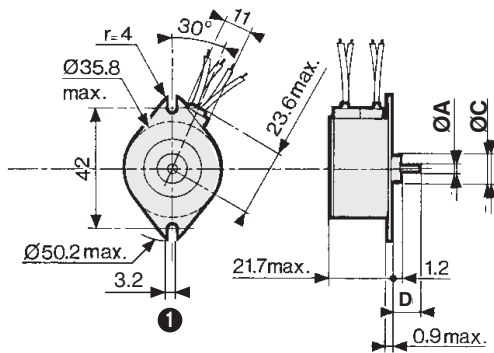

B 2 fixing holes Ø 3.2

Shaft Type	Ø shaft - A	Ø center - C	Length shaft - D
Type 1	2 <sup>-0.002</sup> <sub>-0.006</sub>	9 <sup>-0.010</sup> <sub>-0.060</sub>	9
Type 2	2 <sup>-0.002</sup> <sub>-0.006</sub>	10 <sup>-0.010</sup> <sub>-0.060</sub>	9
Type 3	3.17 <sup>0</sup> <sub>-0.006</sub>	9.52 <sup>-0.010</sup> <sub>-0.060</sub>	9

## Connections

4 phase

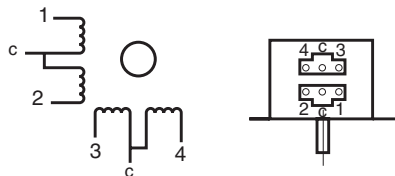

Energization sequence for clockwise rotation : 2 phases energized (viewed from shaft end, front forward)

Products and specifications subject to change without notice.

Order/Technical Support - Tel: (800) 677-5311 / FAX: (800) 677-3865 / www.crouzet-usa.com

# Direct drive stepper motors

→ 15° 5 Watts

- 24 steps/revolution (15°)
- Absorbed power : 5 W
- 2 or 4 phase versions available



## Specifications

	2 phase	4 phase	4 phase
Type	82 910 5	82 910 5	82 910 8
Number of phases	2	4	4
<b>Part numbers</b>	<b>82 910 501</b>	<b>82 910 502</b>	<b>82 910 84H000002</b>
<b>General characteristics</b>			
Electronic controller used	Bipolar	Unipolar	Unipolar
Resistance per phase (Ω)	12.9	115	115
Inductance per phase (mH)	17.3	62	62
Current per phase (A)	0.44	0.14	0.14
Holding torque (mN.m)	20	15	15
Voltage at motor terminals (V)	5.6	17	17
Absorbed power (W)	5	5	5
Step angle (°)	15	15	15
Positioning accuracy (mm)	5	5	5
Inertia of rotor (gcm <sup>2</sup> )	4.9	4.9	4.9
Max. detent torque (mN.m)	3	3	3
Max. coil temperature (°C)	120	120	120
Storage temperature (°C)	-40 → +80	-40 → +80	-40 → +80
Thermal resistance of coil - ambient air (°C/W)	14	14	14
Insulation resistance (at 500 Vcc) (MΩ) following NFC 51200 standard	> 10 <sup>3</sup>	> 10 <sup>3</sup>	> 10 <sup>3</sup>
Bearings	Sintered bronze	Sintered bronze	Plastic
Insulation voltage (50 Hz, 1 minute) (V) following NFC 51200 standard	> 600	> 600	> 600
Wires length (mm)	250	250	250
Weight (g)	90	90	90
Protection rating	IP40	IP 40	IP 40

## Products adaptations, available on request

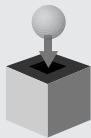

- Special output shafts
- Pinion on output shaft
- Special supply voltages
- Special lead lengths
- Special output bearings
- Customized electronics
- Special construction materials
- Special connectors

Products and specifications subject to change without notice.

Order/Technical Support - Tel: (800) 677-5311 / FAX: (800) 677-3865 / www.crouzet-usa.com

## Curves

Measurement conditions 2 phase :

L 297 298 SGS constant voltage supply board, 5.6 V at motor terminals,  
2 phases energized, full steps, inertia of measuring system 4.53 g.cm<sup>2</sup>

Measurement conditions 4 phase :

89 990 101 constant voltage supply board, 17 V at motor terminals,  
2 phases energized, full steps, inertia of measuring system 4.53 g.cm<sup>2</sup>

Nominal value dynamic curves 2  
phase - 12.9 Ω

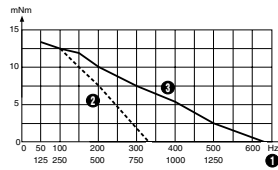

B RPM  
C Stopping-starting  
D Max. operating curves

Nominal value dynamic curves 4  
phase - 115 Ω

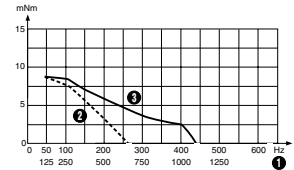

B RPM  
C Stopping-starting  
D Max. operating curves

## Dimensions

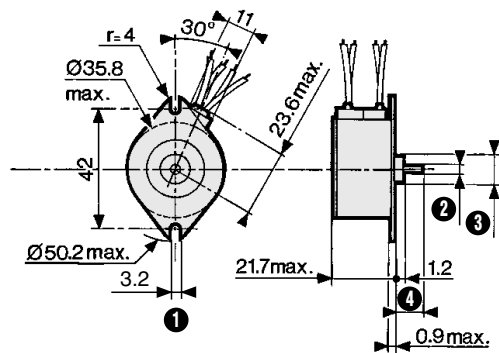

B 2 fixing holes Ø 3.2<sup>+0.10</sup>

Shaft Type	Ø shaft - A	Ø center - C	Length shaft - D
Type 1	2 <sup>-0.002</sup> <sup>-0.006</sup>	9 <sup>-0.010</sup> <sup>-0.060</sup>	9
Type 2	2 <sup>-0.002</sup> <sup>-0.006</sup>	10 <sup>-0.010</sup> <sup>-0.060</sup>	9
Type 3	3.17 <sup>0</sup> <sup>-0.006</sup>	9.52 <sup>-0.010</sup> <sup>-0.060</sup>	9

## Connections

2 phase

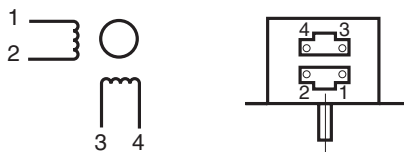

B Step  
Energization sequence for clockwise  
rotation (viewed from shaft end)

4 phase

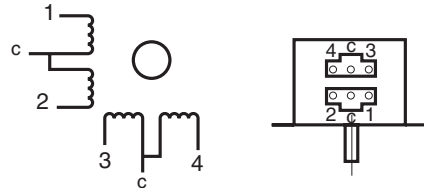

B Step  
Energization sequence for clockwise  
rotation : 2 phases energized (viewed from  
shaft end, front forward)

Products and specifications subject to change without notice.

Order/Technical Support - Tel: (800) 677-5311 / FAX: (800) 677-3865 / www.crouzet-usa.com

# Direct drive stepper motors

→ 7.5° 10 Watts

- 48 steps/revolution (7.5°)
- Absorbed power : 10 W
- 2 or 4 phase versions available



## Specifications

			2 phase	4 phase
Type			82 930 0	82 930 0
Number of phases			2	4
Electronic controller used			Bipolar	Unipolar
<b>Resistance per phase (Ω)</b>	<b>Current per phase (A)</b>	<b>Voltage at motor terminals (V)</b>		
9	0.75	6.6	<b>82 930 2D00000T1 ●</b>	<b>82 930 4D00000T1 ●</b>
22.3	0.48	10.4	<b>82 930 002</b>	<b>82 930 015</b>
<b>General characteristics</b>				
Absorbed power (W)			10	10
Holding torque (mN.m)			180	155
Step angle (°)			7.5	7.5
Positioning accuracy (mm)			5	5
Inertia of rotor (gcm <sup>2</sup> )			84	84
Max. detent torque (mN.m)			12	12
Max. coil temperature (°C)			120	120
Storage temperature (°C)			-40 → +80	-40 → +80
Thermal resistance of coil - ambient air (°C/W)			7	7
Insulation resistance (at 500 Vcc) (MΩ) following NFC 51200 standard			> 10 <sup>3</sup>	> 10 <sup>3</sup>
Insulation voltage (50 Hz, 1 minute) (V) following NFC 51200 standard			> 600	> 600
Wires length (mm)			250	250
Weight (g)			340	340
Protection rating			IP40	IP40

## Products adaptations, available on request

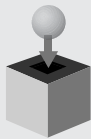

- Special output shafts
- Pinion on output shaft
- Special supply voltages
- Special lead lengths
- Special output bearings
- Customized electronics
- Special construction materials
- Special connectors

Products and specifications subject to change without notice.

Order/Technical Support - Tel: (800) 677-5311 / FAX: (800) 677-3865 / www.crouzet-usa.com

## Curves

Inertia of measuring chain : 3.4 g.cm<sup>2</sup>

a = constant voltage controller with R<sub>s</sub> (resistance in series) = 0

b = constant voltage controller with R<sub>s</sub> (resistance in series) = R motor

c = constant voltage controller with R<sub>s</sub> (resistance in series) = 2R motor

d = constant voltage controller with R<sub>s</sub> (resistance in series) = 3R motor

The measurements are made with full stepping, 2-phases energized.

2 phase

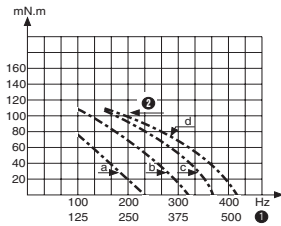

B RPM  
C Max. stopping-starting curves

2 phase - Max. stopping-starting and operating curves at I constant (PBL 3717) for 2 (motor) phases 9 Ω

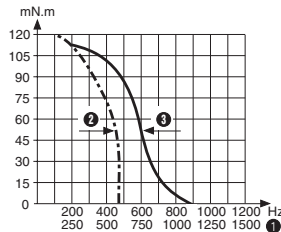

B RPM  
C Max. stopping-starting curves  
D Max. operating curves

Max. stopping-starting frequency curves as a function of the external inertia load at zero antagonistic torque. Tests at constant U.

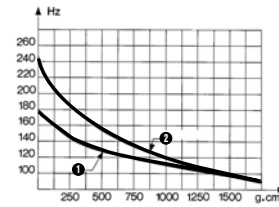

B 2 phases  
C 4 phases

4 phase

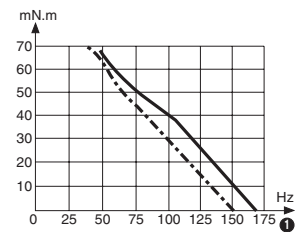

B RPM  
C Max. stopping-starting curves

## Dimensions

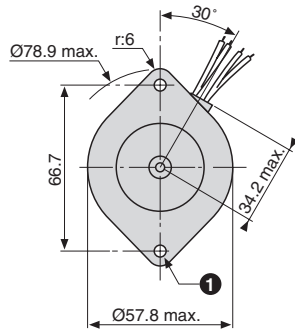

B 2 Fixing holes Ø 4.4

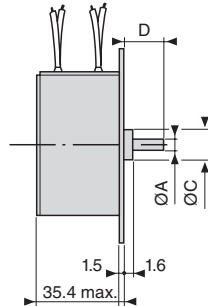

Shaft Type	Ø shaft - A	Ø center - C	Length shaft - D
Type 1	4 <sup>0</sup> <sub>-0.008</sub>	12 <sup>0</sup> <sub>-0.05</sub>	16
Type 2	6.35 <sup>0</sup> <sub>-0.01</sub>	11.13 <sup>0</sup> <sub>-0.05</sub>	19
Type 3	6.35 <sup>0</sup> <sub>-0.01</sub>	12.7 <sup>0</sup> <sub>-0.05</sub>	19

## Connections

2 phases

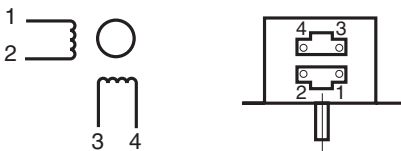

Energization sequence for clockwise rotation : (viewed shaft end)

4 phases

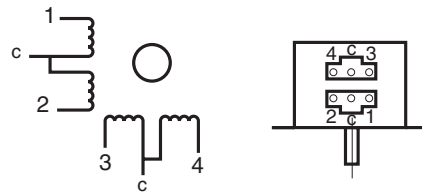

Energization sequence for clockwise rotation : 2 phases energized (viewed shaft end, front forward)

Products and specifications subject to change without notice.

Order/Technical Support - Tel: (800) 677-5311 / FAX: (800) 677-3865 / www.crouzet-usa.com

# Direct drive stepper motors

→ 7.5° 7.5 Watts

- 48 steps/revolution (7.5°)
- Absorbed power : 7.5 W
- 2 or 4 phase versions available



## Specifications

			2 phase	4 phase
Type			82 920 0	82 920 0
Number of phases			2	4
Electronic controller used			Bipolar	Unipolar
<b>Resistance per phase (Ω)</b>	<b>Current per phase (A)</b>	<b>Voltage at motor terminals (V)</b>		
10.7	0.59	6.3	<b>82 920 001</b>	<b>82 920 4G000001 ●</b>
46	0.28	12.9	<b>82 920 2F000001 ●</b>	<b>82 920 012</b>
<b>General characteristics</b>				
Absorbed power (W)			7.5	7.5
Holding torque (mN.m)			70	57
Step angle (°)			7.5	7.5
Positioning accuracy (mm)			5	5
Inertia of rotor (gcm <sup>2</sup> )			18.8	18.8
Max. detent torque (mN.m)			6	6
Max. coil temperature (°C)			120	120
Storage temperature (°C)			-40 → +80	-40 → +80
Thermal resistance of coil - ambient air (°C/W)			9.3	9.3
Insulation resistance (at 500 Vcc) (MΩ) following NFC 51200 standard			> 10 <sup>3</sup>	> 10 <sup>3</sup>
Insulation voltage (50 Hz, 1 minute) (V) following NFC 51200 standard			> 600	> 600
Wires length (mm)			250	250
Weight (g)			210	210
Protection rating			IP40	IP 40

## Products adaptations, available on request

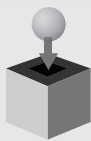

- Special output shafts
- Pinion on output shaft
- Special supply voltages
- Special lead lengths
- Special output bearings
- Customized electronics
- Special construction materials
- Special connectors

Products and specifications subject to change without notice.

Order/Technical Support - Tel: (800) 677-5311 / FAX: (800) 677-3865 / www.crouzet-usa.com

## Curves

Inertia of measuring chain : 2.2 g.cm<sup>2</sup>

a = constant voltage controller with R<sub>s</sub> (resistance in series) = 0

b = constant voltage controller with R<sub>s</sub> (resistance in series) = R motor

c = constant voltage controller with R<sub>s</sub> (resistance in series) = 2R motor

d = constant voltage controller with R<sub>s</sub> (resistance in series) = 3R motor

The measurements are made with full stepping, 2-phases energized.

2 phase

2 phases - Max. stopping-starting and operating curves at I constant (PBL 3717) for 2 (motor) phases 12.9 Ω

Max. stopping-starting frequency curves as a function of the external inertia load at zero antagonistic torque. Tests at constant U.

4 phase

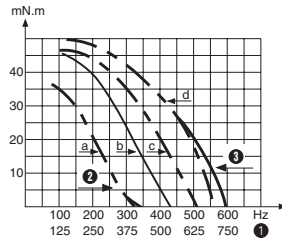

B RPM  
C Max. stopping-starting curves  
D Max. operating curves

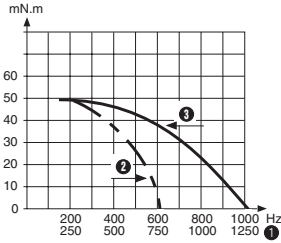

B RPM  
C Max. stopping-starting curves  
D Max. operating curves

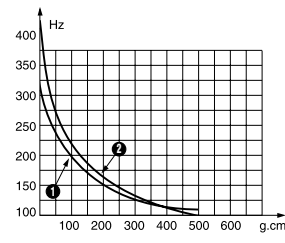

B 2 phases  
C 4 phases

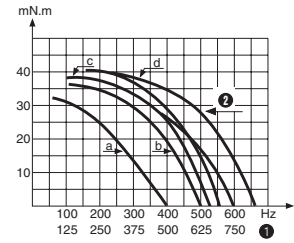

B RPM  
C Max. operating curves

## Dimensions

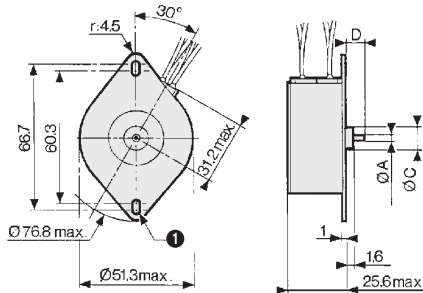

Shaft Type	Ø shaft - A	Ø center - C	Length shaft - D
Type 1	2 <sup>0</sup> <sub>-0.006</sub>	9 <sup>-0.010</sup> <sub>-0.050</sub>	9
Type 2	2 <sup>0</sup> <sub>-0.006</sub>	10 <sup>-0.010</sup> <sub>-0.050</sub>	9
Type 3	3.17 <sup>0</sup> <sub>-0.006</sub>	9.52 <sup>-0.010</sup> <sub>-0.050</sub>	9

B 2 oblong fixing holes : wide 3.5

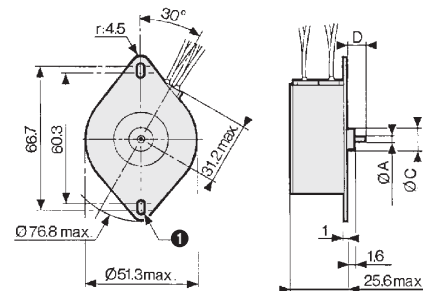

B 2 oblong fixing holes : wide 3.5

## Connections

2 phase

	1	2	3	4
1	-	+	-	+
2	-	+	+	-
3	+	-	+	-
4	+	-	-	+
5	-	+	-	+

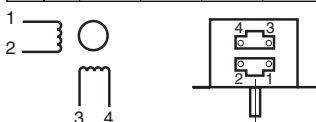

B Step  
Energization sequence for clockwise rotation : (viewed shaft end)

4 phase

	1	2	3	4
1	-	-	-	-
2	-	-	-	-
3	-	-	-	-
4	-	-	-	-
5	-	-	-	-

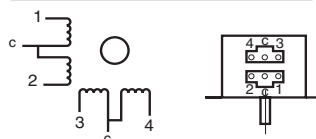

B Step  
Energization sequence for clockwise rotation : 2 phases energized (viewed shaft end, front forward)

Products and specifications subject to change without notice.

# Direct drive stepper motors

→ 7.5° 12.5 Watts

- 48 steps/revolution (7.5°)
- Absorbed power : 12.5 W
- 2 or 4 phase versions available

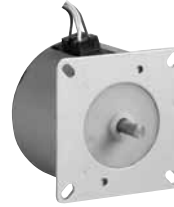

## Specifications

			2 phase	4 phase
Type			82 940 0	82 940 0
Number of phases			2	4
Electronic controller used			Bipolar	Unipolar
<b>Resistance per phase (Ω)</b>	<b>Current per phase (A)</b>	<b>Voltage at motor terminals (V)</b>		
5.2	1.1	5.7	<b>82 940 2I000001 ●</b>	<b>82 940 015</b>
26.7	0.48	12.7	<b>82 940 002</b>	<b>82 940 2J000001 ●</b>
<b>General characteristics</b>				
Absorbed power (W)			12.5	12.5
Holding torque (mN.m)			300	240
Step angle (°)			7.5	7.5
Positioning accuracy (mm)			5	5
Inertia of rotor (gcm <sup>2</sup> )			180	180
Max. detent torque (mN.m)			16	16
Max. coil temperature (°C)			120	120
Storage temperature (°C)			-40 → +80	-40 → +80
Thermal resistance of coil - ambient air (°C/W)			5.6	5.6
Insulation resistance (at 500 Vcc) (MΩ) following NFC 51200 standard			> 10 <sup>3</sup>	> 10 <sup>3</sup>
Insulation voltage (50 Hz, 1 minute) (V) following NFC 51200 standard			> 600	> 600
Wires length (mm)			250	250
Weight (g)			540	540
Protection rating			IP40	IP 40

## Products adaptations, available on request

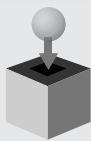

- Special output shafts
- Pinion on output shaft
- Special supply voltages
- Special lead lengths
- Special output bearings
- Customized electronics
- Special construction materials
- Special connectors

Products and specifications subject to change without notice.

Order/Technical Support - Tel: (800) 677-5311 / FAX: (800) 677-3865 / www.crouzet-usa.com

## Curves

Inertia of measuring chain : 20.5 g.cm<sup>2</sup>

a = constant voltage controller with R<sub>s</sub> (resistance in series) = 0

b = constant voltage controller with R<sub>s</sub> (resistance in series) = R motor

c = constant voltage controller with R<sub>s</sub> (resistance in series) = 2R motor

d = constant voltage controller with R<sub>s</sub> (resistance in series) = 3R motor

The measurements are made with full stepping, 2-phases energized.

2 phase

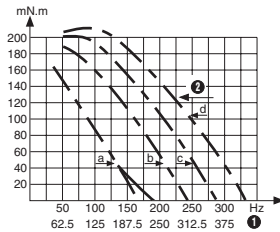

B RPM  
C Max. stopping-starting curves

2 phase - Max. stopping-starting and operating curves at I constant (PBL 3717) for 2 (motor) phases 5.2 Ω

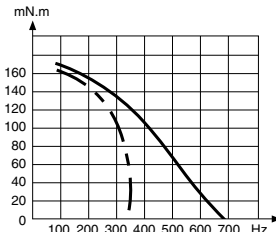

B Max. stopping-starting curves  
C Max. operating curves

Max. stopping-starting frequency curves as a function of the external inertia load at zero antagonistic torque. Tests at constant U.

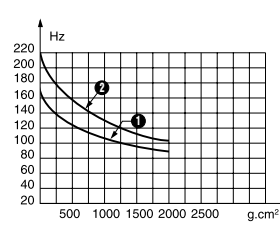

B 2 phases  
C 4 phases

4 phase

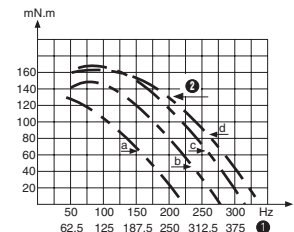

B RPM  
C Max. stopping-starting curves

## Dimensions

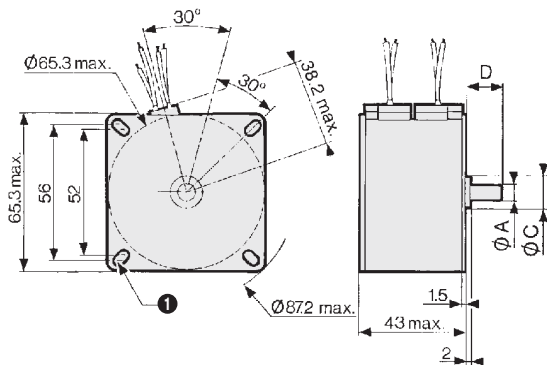

B 4 oblong fixing holes 4.2 wide

Shaft Type	Ø shaft - A	Ø center - C	Length shaft - D
Type 1	6 <sup>0</sup> <sub>-0.008</sub>	12 <sup>0</sup> <sub>-0.050</sub>	15
Type 2	6.35 <sup>0</sup> <sub>-0.01</sub>	12.7 <sup>0</sup> <sub>-0.050</sub>	15
Type 3	6.35 <sup>0</sup> <sub>-0.01</sub>	14 <sup>0</sup> <sub>-0.050</sub>	15

## Connections

2 phase

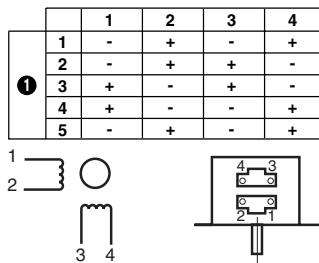

B Step  
Energization sequence for clockwise rotation : (viewed shaft end)

4 phase

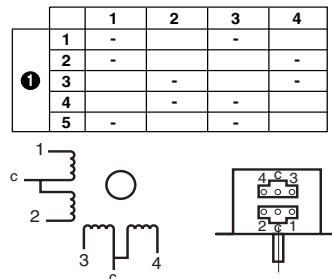

B Step  
Energization sequence for clockwise rotation : 2 phases energized (viewed shaft end, front forward)

Products and specifications subject to change without notice.

Order/Technical Support - Tel: (800) 677-5311 / FAX: (800) 677-3865 / www.crouzet-usa.com

# Geared stepper motors

→ 0.5 Nm 5 and 7.5 Watts

- Mechanical strength: 0.5 Nm
- Various ratios available
- 2 or 4 phase versions available



## Specifications

	7.5 Watts	7.5 Watts	5 Watts	5 Watts	5 Watts	5 Watts
Type	82 924 0	82 924 0	82 914 8	82 914 8	82 914 3	82 914 3
Number of phases	2	4	2	4	2	4
<b>Ratios</b>						
10	82 924 020	82 924 028	●	●	●	●
20	82 924 022	82 924 030	●	●	●	●
25	●	●	●	●	●	●
50	●	●	●	●	●	●
100	●	●	●	●	●	●
250	●	●	●	●	●	●
500	●	●	-	-	-	-
<b>General characteristics</b>						
Stepper motor	82 920 001	82 920 012	82 910 8	82 910 8	82 910 3	82 910 3
Gearbox	81 021	81 021	81 021	81 021	81 021	81 021
Step angle (°)	7.5	7.5	15	15	7.5	7.5
Maximum permitted torque from gearmotor under continuous conditions (N.m)	0.5	0.5	0.5	0.5	0.5	0.5
Axial load static (daN)	1	1	1	1	1	1
Radial load static (daN)	8	8	8	8	8	8
Absorbed power (W)	7.5	7.5	5	5	5	5
Coil temperature (°C)	120	120	120	120	120	120
Weight (g)	140	140	140	140	140	140
Wires length (mm)	250	250	250	250	250	250
Protection rating	IP40	IP40	IP40	IP40	IP40	IP40

## Products adaptations, available on request

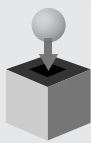

- Special output shafts
- Special supply voltages
- Special lead lengths
- Special output bearings
- Customized electronics
- Special construction materials
- Special connectors
- Special gearbox ratios
- Special mounting plate
- Special gear material

Products and specifications subject to change without notice.

Order/Technical Support - Tel: (800) 677-5311 / FAX: (800) 677-3865 / [www.crouzet-usa.com](http://www.crouzet-usa.com)

## Dimensions

82 924 0

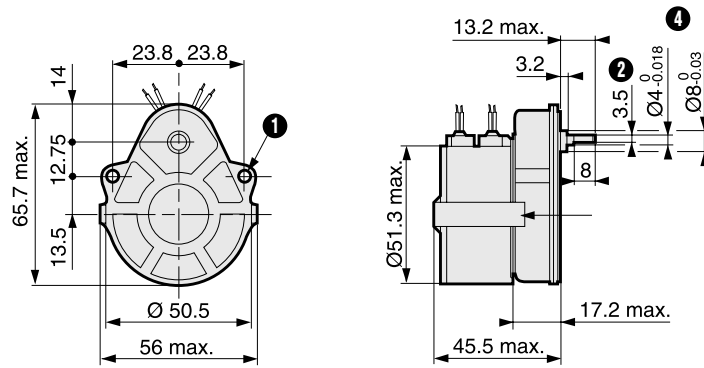

- B 2 fixing holes  $\varnothing$  3.2
- C 3.5 across flat
- D (pushed-in shaft ←)

82 914 0 - 82 914 5

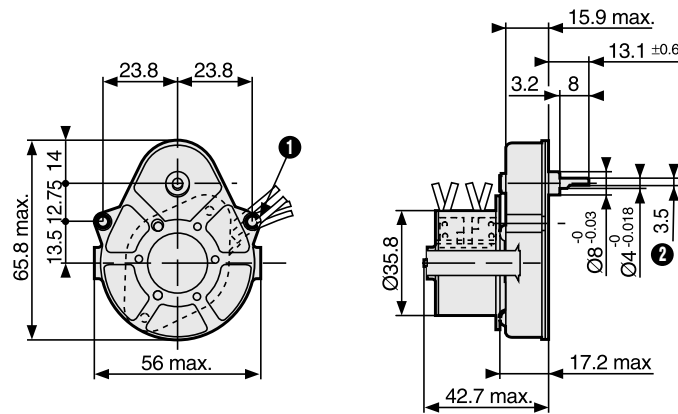

- B 2 fixing holes  $\varnothing$  3.2
- C 3.5 across flat

82 914 0 = L max. 39.5  
82 914 5 = L max. 42.7

## Options

Optional shafts for 81 021  
79 200 967

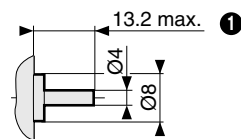

B (Pushed-in shaft ←)

79 200 779

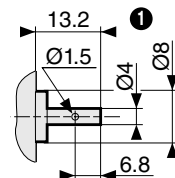

B (Pushed-in shaft ←)

70 999 421  
SP 1295-10

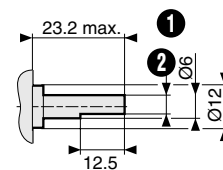

B (Pushed-in shaft ←)  
C 5 across flat

## Other information

Other versions are possible to special order in reasonable quantities :

- other reduction ratios
- special shafts
- different exit angle for leads
- special grease
- mounting by M3 tapped holes
- motor screw-assembled not clip jointed
- available with other gearboxes in the Crouzet range
- available with 82 930 basic motors (82 934 0 and 82 939 0)

Products and specifications subject to change without notice.

Order/Technical Support - Tel: (800) 677-5311 / FAX: (800) 677-3865 / www.crouzet-usa.com

# Geared stepper motors

→ 2 Nm 5 and 7.5 Watts

- Mechanical strength : 2 Nm
- Various ratios available
- 2 or 4 phase versions available



## Specifications

	7.5 Watts	7.5 Watts	5 Watts	5 Watts	5 Watts	5 Watts
Type	82 929 0	82 929 0	82 919 8	82 919 8	82 919 3	82 919 3
Number of phases	2	4	2	4	2	4
<b>Ratios</b>						
25	●	●	●	●	●	●
50	●	●	●	●	●	●
100	●	●	●	●	●	●
250	●	●	●	●	●	●
<b>General characteristics</b>						
Stepper motor / Number of phases	82 920 001	82 920 012	82 910 8	82 910 8	82 910 3	82 910 3
Gearbox	81 033	81 033	81 033	81 033	81 033	81 033
Step angle (°)	7.5	7.5	15	15	7.5	7.5
Maximum permitted torque from gearmotor under continuous conditions (N.m)	2	2	2	2	2	2
Axial load static (daN)	1	1	1	1	1	1
Radial load static (daN)	10	10	10	10	10	10
Absorbed power (W)	7.5	7.5	5	5	5	5
Coil temperature (°C)	120	120	120	120	120	120
Weight (g)	260	260	140	140	230	230
Wires length (mm)	250	250	250	250	250	250
Protection rating	IP 40	IP 40	IP 40	IP 40	IP 40	IP 40

## Products adaptations, available on request

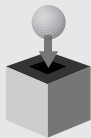

- Special output shafts
- Special supply voltages
- Special lead lengths
- Special output bearings
- Customized electronics
- Special construction materials
- Special connectors
- Special gearbox ratios
- Special mounting plate
- Special gear material

Products and specifications subject to change without notice.

Order/Technical Support - Tel: (800) 677-5311 / FAX: (800) 677-3865 / [www.crouzet-usa.com](http://www.crouzet-usa.com)

## Dimensions

82 929 0

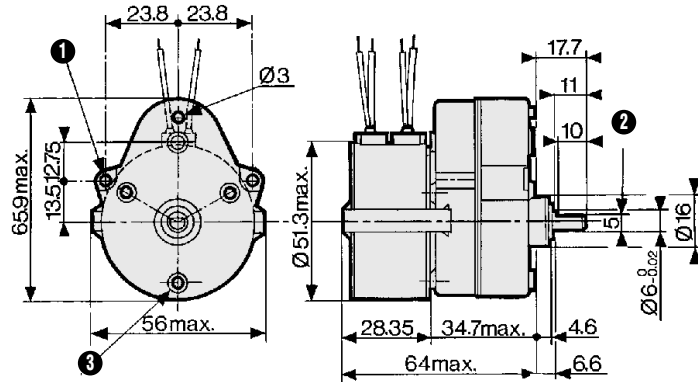

- B 2 fixing holes Ø 3.2
- C 5 across flat
- D 3 mounting bosses Ø 6.8 at 120° on radius = 19.5 3 holes M3 depth 4.5

82 919 0 - 82 919 5

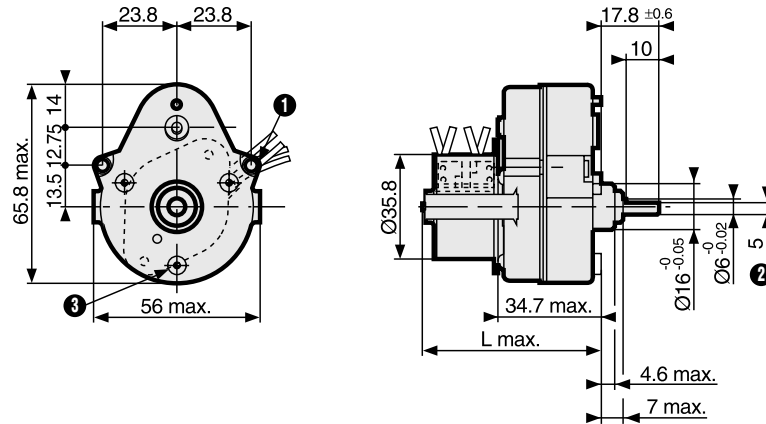

- B 2 fixing holes Ø 3.2
- C 5 across flat
- D 3 mounting bosses Ø 6.8 at 120° on radius = 19.5 3 holes M3 depth 4.5

82 919 0 = L max. 58.5  
82 919 5 = L max. 60.2

## Options

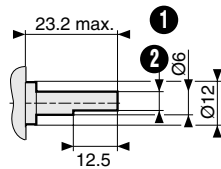

- B (Pushed-in shaft ←)
- C 5 across flat

Products and specifications subject to change without notice.

Order/Technical Support - Tel: (800) 677-5311 / FAX: (800) 677-3865 / www.crouzet-usa.com

# Geared stepper motors

→ 5 Nm 5 and 7.5 Watts

- Mechanical strength : 5 Nm
- Various ratios available
- 2 or 4 phase versions available



## Specifications

	5 Watts	7.5 Watts	7.5 Watts
Number of phases	2 / 4	2	4
<b>Ratios</b>			
12.5	●	<b>80 927 019</b>	<b>80 927 020</b>
25	●	●	●
31.25	●	●	●
41.66	●	●	●
62.5	●	●	●
83.33	●	●	●
125	●	●	●
250	●	<b>80 927 006</b>	●
500	●	●	●
750	●	●	●
2500	●	●	●
<b>General characteristics</b>			
Motor	82 910 0	82 920 001	82 920 012
Gearbox	81 037	81 037	81 037
Maximum permitted torque from gearmotor under continuous conditions (N.m)	5	5	5
Number of phases	2/4	2	4
Axial load static (daN)	2	2	2
Radial load static (daN)	3	3	3
Absorbed power (W)	5	7.5	7.5
Coil temperature (°C)	120	120	120
Weight (g)	410	530	530
Wires length (mm)	250	250	250
Protection rating	IP 40	IP 40	IP 40

## Products adaptations, available on request

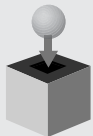

- Special output shafts
- Special supply voltages
- Special lead lengths
- Special output bearings
- Customized electronics
- Special construction materials
- Special connectors
- Special gearbox ratios
- Special mounting plate
- Special gear material

Products and specifications subject to change without notice.

Order/Technical Support - Tel: (800) 677-5311 / FAX: (800) 677-3865 / [www.crouzet-usa.com](http://www.crouzet-usa.com)



# Geared stepper motors

→ 3 Nm 2.5 and 3.5 Watts

- Mechanical strength: 3 Nm
- Various ratios available
- 2 or 4 phase versions available



## Specifications

	2.5 Watts	2.5 Watts	3.5 Watts	3.5 Watts
Type	80 913 0	80 913 5	80 923 0	80 933 0
<b>Ratios</b>				
150	●	●	●	●
187.5	●	●	●	●
300	●	●	●	●
375	●	●	●	●
600	●	●	●	●
750	●	●	●	●
1200	●	●	●	●
2250	●	●	●	●
2400	●	●	●	●
3600	●	●	●	●
<b>General characteristics</b>				
Motor	82 910 0	82 910 5	82 920	82 930
Gearbox	81 023 0	81 023 0	81 023 0	81 023 0
Maximum permitted torque from gearmotor under continuous conditions (N.m)	3	3	3	3
Axial load static (daN)	2	2	2	2
Radial load static (daN)	3	3	3	3
Absorbed power (W)	2.5	2.5	3.5	3.6
Weight (g)	370	370	490	620
Wires length (mm)	250	250	250	250
Protection rating	IP00	IP00	IP00	IP00

## Products adaptations, available on request

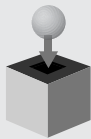

- Special output shafts
- Special supply voltages
- Special lead lengths
- Special output bearings
- Customized electronics
- Special construction materials
- Special connectors
- Special gearbox ratios
- Special mounting plate
- Special gear material

Products and specifications subject to change without notice.

Order/Technical Support - Tel: (800) 677-5311 / FAX: (800) 677-3865 / [www.crouzet-usa.com](http://www.crouzet-usa.com)

# Dimensions

80 913 0/5

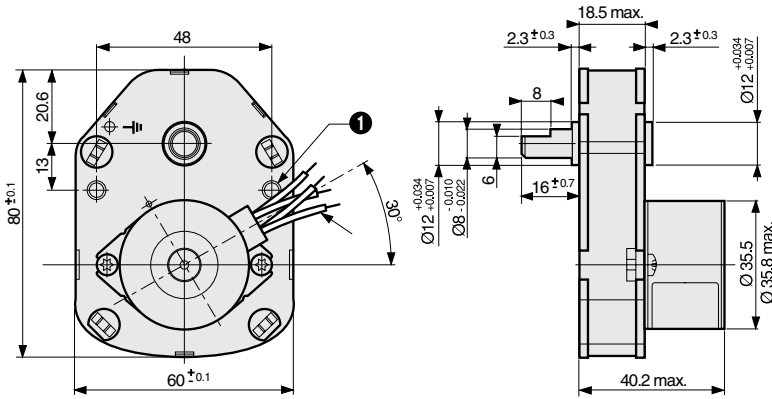

80 923 0

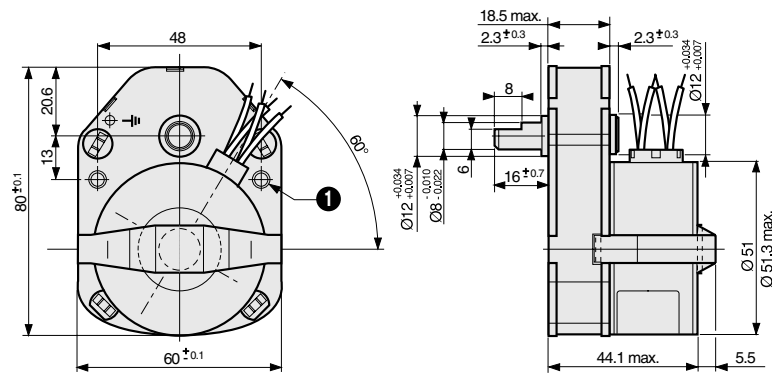

80 933 0

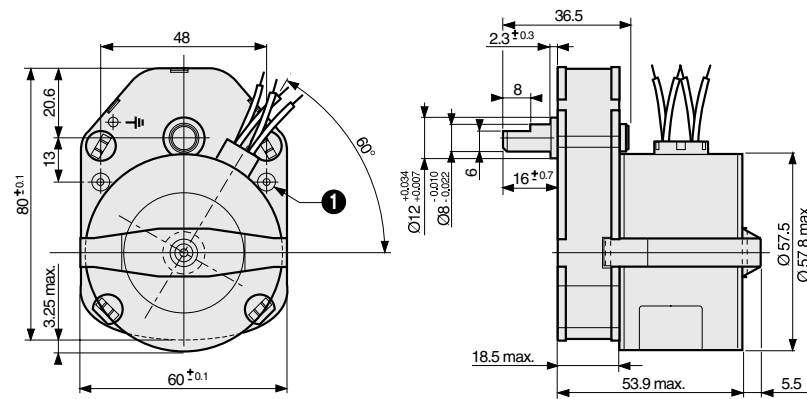

Products and specifications subject to change without notice.

Order/Technical Support - Tel: (800) 677-5311 / FAX: (800) 677-3865 / [www.crouzet-usa.com](http://www.crouzet-usa.com)

# Geared stepper motors

→ 5 Nm 12.5 Watts

- Mechanical strength : 5 Nm
- Various ratios available
- 2 or 4 phase versions available



## Specifications

	12.5 Watts	12.5 Watts
Type	80 947 0	80 947 0
Number of phases	2	4
<b>Ratios</b>		
12.5	<b>80 947 019</b>	<b>80 947 020</b>
25	<b>80 947 001</b>	<b>80 947 010</b>
31.25	●	●
41.66	●	●
62.5	●	●
83.33	●	●
125	●	●
250	●	●
500	●	●
750	●	●
2500	●	●
<b>General characteristics</b>		
Motor	82 940 002	82 940 015
Gearbox	81 037	81 037
Maximum permitted torque from gearmotor under continuous conditions (N.m)	5	5
Number of phases	2	4
Axial load static (daN)	2	2
Radial load static (daN)	3	3
Absorbed power (W)	12.5	12.5
Coil temperature (°C)	120	120
Weight (g)	860	860
Wires length (mm)	250	250
Protection rating	IP 40	IP 40

## Products adaptations, available on request

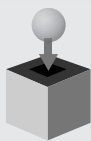

- Special output shafts
- Special supply voltages
- Special cable lengths
- Special output bearings
- Customized electronics
- Special construction materials
- Special connectors
- Special gearbox ratios
- Special mounting plate
- Special gear material

Products and specifications subject to change without notice.

Order/Technical Support - Tel: (800) 677-5311 / FAX: (800) 677-3865 / [www.crouzet-usa.com](http://www.crouzet-usa.com)

## Dimensions

80 947 0

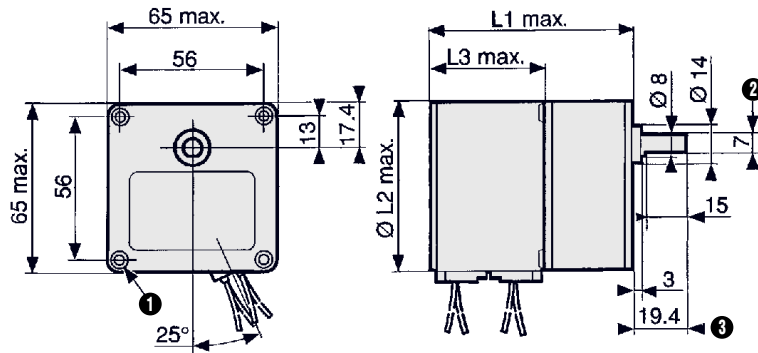

B 4 holes M4 depth 12

C across flat

D (pushed-in shaft ←)

80 947 0 = L1 : 76.6 mm - ØL2 : 65.3 mm - L3 : 43 mm

## Options

Shaft 79 206 478

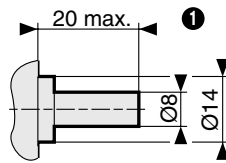

B (pushed-in shaft ←)

Products and specifications subject to change without notice.

Order/Technical Support - Tel: (800) 677-5311 / FAX: (800) 677-3865 / [www.crouzet-usa.com](http://www.crouzet-usa.com)