

## TP-102 Series

Single Hole, Printed Circuit Mounted Test Points

### Specifications

**Materials:**

**Contact Material:** .020" diameter phosphor bronze #510 alloy

**Finish:** .0001 Matte Tin over .00005 Nickel

**Mechanical:**

**Mounting Holes:**

TP-102-01 = .067" to .078" diameter

TP-102-02 = .112" to .116" diameter

**Electrical:**

**Maximum Current:** 2.0 amperes

**Special Notations:**

A convenient, inexpensive hand tool (model #1020) is available to facilitate placement of TP-102 test points during assembly operations.

Home

>>Products

>> Through Hole

Surface Mount

Custom Wireform

News

About Us

Distributor &  
Representative  
Search

Contact Us

Check Stock

Compliance

Site Map

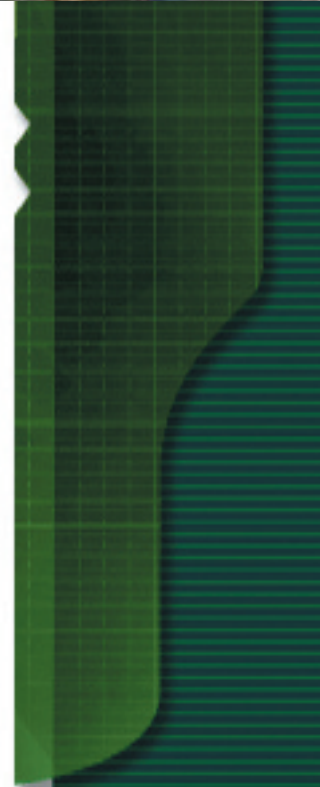

## TP-102 Contacts

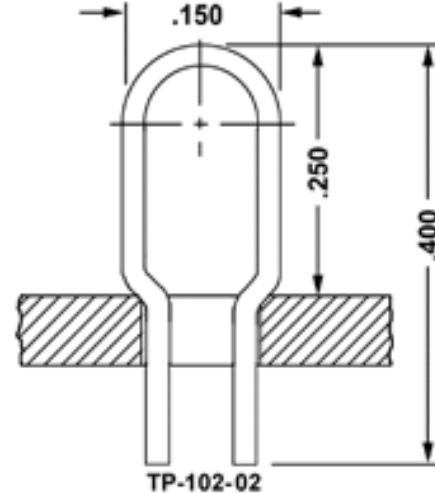
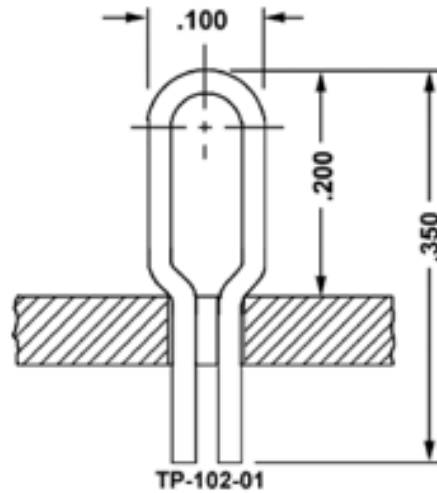

## Ordering Information

Example

TP - 102 - 01 - T

● **Series Designation:**  
TP-102

● **Hole Diameter Range:**  
01 = .067" - .080"  
02 = .112" - .116"

● **Finish:**  
Matte Tin over Nickel

## Product Description

---

The TP-102 series of printed circuit mounted, test point jumpers provides a significantly lower cost and superior function to that of conventional "turret" type terminals in board level, "trouble shooting" applications. With only two part number types, the TP-102 series covers the complete range of hole diameters most commonly employed for "turret" terminals; the need for costly re-design of circuit board art work is eliminated.

Spring tempered, flared leads allow sufficient tension positioning in the hole during wave soldering, thereby eliminating the costly staking or secondary soldering operations normally encountered with "turret" terminals.

The unique loop profile of the TP-102 series offers a superior and positive anchor for commonly used, spring loaded test probes and clips. The economies and single hole mounting requirement of this design permit greater numbers of test point locations in p.c. board applications at much less expense than previously used "turret" terminals.

The TP-102 series devices are formed from phosphor bronze alloy wire. Due to the spring temper and flared lead design, only two styles are necessary to cover mounting hole diameters from .067" to .078" and .112" to .116".

### **Certificate of Compliance with Directive 2002/95/EC RoHS**

This is to certify that Components Corporation designs, manufactures and supplies products to our customers that are in compliance with directive 2002/95/EC. This also pertains to procurement of raw material, component parts and processes.



Top  
of Page

Open this page as a PDF document

**Components Corporation**

6 Kinsey Place Denville, NJ 07834 USA

**voice:** 866.4.COMPCO **fax:** 973.361.5801 **email:** sales@componentscorp.com

©2003 Components Corporation. All Rights Reserved. Legal Statement. Privacy Notice.