

The **PTM-300 Series** Pulse Timing Module can solve timing issues in many sensor timing and control applications. Pulses may be accepted from standard sensor outputs, such as Proximity and Photo-sensors. User control is provided for pulse timing in 1 milliseconds increments. Standard timing functions include EXTEND Pulses, STRETCH or SHORTEN Pulses, detect signal activity i.e. MOTION, DELAY-ON, DELAY-OFF, INTERVAL timing, and BUFFER modes.

The **PTM-300 Series** automatically detects the polarity of the input signal (either **PNP sourcing** or **NPN sinking**) and produces an output of the same polarity. The complimentary output polarity \bar{x} is also user selectable.

The *model PTM-300U* provides an LCD display and user controls for simple time/function configuration, as well as 'on-the-fly' timing \blacktriangle \blacktriangledown adjustments in 1mS and 100mS steps^{2,3}. Real-time STATUS LEDs are provided to indicate Input and Output signal status and polarity, as well as active Timing status (●) for display of operation at a glance.

Standard features include: 10-30Vdc operation, Auto-detect [I/O²] Input polarity, Single output for both **PNP sourcing** and **NPN sinking** signal polarity (short-circuit protected), low-profile 8-pin octal plug-in and encapsulated timing circuitry for industrial reliability. Many other options and configurations are available.

Features

- **Auto-Detected [I/O²] Input (PNP/NPN)**
- **Timing control in 1mS Increments²**
- **Timing Range - 10mS to 60 Seconds¹**
- **Wide 10 to 30 VDC Operation**
- **Encapsulated Timing Circuitry**
- **Sink/Source SSR Output (protected)**
- **'Real-Time' Status Indicators**
- **Industry Standard 8 Pin Octal Plug-in**
- **Low-Profile 8-pin Octal 2"sq Package**
- **User Configurable w/LCD Display³**
- **'On-the-Fly' Timing Adjustment³**

¹ Consult factory for other timing ranges and functions.

² Timing resolution: 1mS (10 to 999mS range), 100mS (1 to 60 Seconds range).

³ PTM-300U Models are user-configurable and include LCD Display and 'on-the-fly' timing adjust. (see [Operation](#) on sheet 2)

Patent Pending

PTM-300 Series™

Pulse Timing Module

PULSE INPUT



PNP/NPN (or DRY)
SINKING or SOURCING

OPTIONAL
OPTO-ISOLATED
INPUT

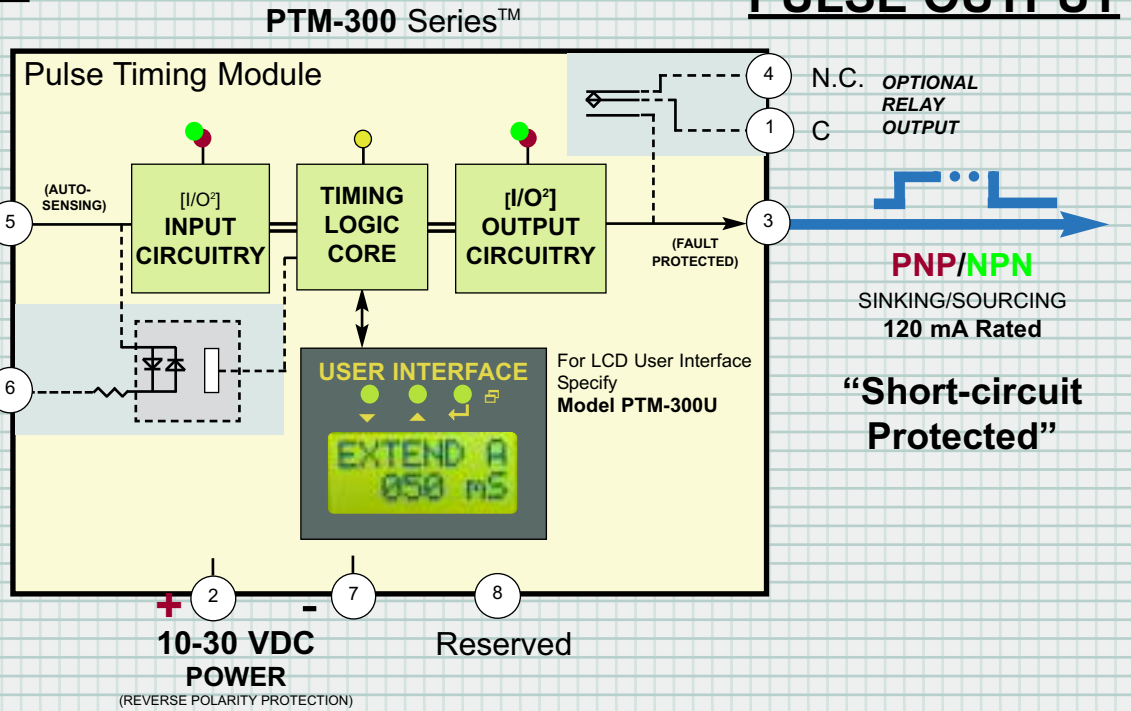

PULSE OUTPUT

PNP/NPN
SINKING/SOURCING
120 mA Rated

**“Short-circuit
Protected”**

Operation

Input signals, such as ‘Open-Collector’ PNP/NPN types or DRY Contact closures are received from sources such as proximity sensors, photo-sensors, etc. at input (Pin 5), (Other signals, such as TTL, CMOS logic and bi-polar types require the -ISO or -ISO5 opto-isolated input option). Input signal polarity is automatically detected by the input circuitry and indicated by the INPUT LED ● PNP/● NPN. The desired timed output is produced at output (Pin 3) in the same signal polarity as the detected input signal. The output polarity and status is indicated by the OUTPUT LED ● PNP/● NPN. (Example - An NPN input signal is *automatically* matched as an NPN output signal and likewise, a PNP input signal produces a matching PNP signal output). In user-selectable \bar{x} mode, the output polarity is the *compliment* of the input polarity. (For example, in \bar{x} mode, an NPN input signal will produce a PNP output signal and likewise, a PNP input signal will produce an NPN output signal.) The TIMING ● LED indicates actual timing activity of the Pulse Timing Module in ‘real-time’.

The ‘fault protected’ solid state output can source or sink up to 120mA loads. If the output (Pin 3) is shorted, producing an ‘over-current’ condition, the LCD display will display “OUTPUT FAULTED” and the PTM-300 will roll-back the output current until the fault condition is cleared. Note: an indefinite short-circuit condition on Pin 3 to Ground or Pin 3 to V+ will not cause device damage.

The user-adjustable timing range is from 10 millisecond to 999 milliseconds in 1 mS increments and from 1 second to 60 seconds in 100 mS (0.1 second) increments. Single-step timing changes may be made in real time UP or DOWN by simply pressing the ▲ or ▼ buttons. All TIME/FUNCTION settings are retained when power is lost. However, ‘on-the-fly’ timing adjustments of less than 500mS will be stored by entering and exiting CONFIG ⏏ Mode.

Electrical Specifications

(Standard Models)

SYMBOL	PARAMETER	LIMITS			UNIT	CONDITION
		MIN	TYP	MAX		
$V_{op, V+}$	Operating Supply Voltage	10		30	VDC	Pins 2 & 7, Note 1
I_{supply}	Power supply Current		50	75	mA	No Output load current.
I_L	Output Load Current	0		125	mA	Pin 3
I_{sc}	Output Short-circuit current		140	175	mA	Pin 3, Note 2
Z_{in}	Input Impedance	1	1.2		K Ω	Pin 5
V_{in}	Voltage on Input	-5v		$V_{op}+5v$		Pin 5
T_{op}	Operating Temperature	0		+50	°C	

Notes:

1. Reverse polarity protected.
2. Protected against fault in either polarity (sourcing or sinking).

Timing Modes & Functions

(Standard Models)

PULSE/TIMING FUNCTION	TIMING MODE(S)							Description
	STRETCH	INTERVAL	EXTEND	MOTION	WATCHDOG	BUFFER	DELAY-ON	
<ul style="list-style-type: none"> ● Increase Pulse Width / ● Decrease Pulse Width (One-Shot/non-retriggerable) 	✗	✗						Produces a single output pulse of desired width triggered by the ON-EDGE of the pulse input. Set time to desired output Pulse Width (T_{pw}).
<ul style="list-style-type: none"> ● Extend Pulse On Time (retriggerable) 			✗					Adds desired time to the trailing edge (OFF-EDGE) of the input pulse. Output pulse = Input pulse time + 'extended' time (T).
<ul style="list-style-type: none"> ● Motion Detect / ● Watchdog Timer (One-Shot/retriggerable) 				✗				Timer is triggered/retriggered by each ON-EDGE of input pulse detected. Output is ON while timing is active. Output times-out from last ON-EDGE of input pulse detected.
<ul style="list-style-type: none"> ● Buffer Pulse Output = Input 					✗			In BUFFER mode, timing is set to 0 mS. The output produced matches the input for virtually 'transparent' operation.
<ul style="list-style-type: none"> ● Delay-ON-Make Delayed output 						✗		Delay of output for desired delay time. Output is OFF until input is ON for set time; then output remains on until input signal is OFF.
<ul style="list-style-type: none"> ● Delay-OFF 							✗	Output turns ON when Input turns ON. Output remains ON for the desired time after input turns OFF.

Timing Specifications

(Standard Models)

SYMBOL	PARAMETER	LIMITS			UNIT	CONDITION
		MIN	TYP	MAX		
$T_{pw(MIN)}$	Minimum Input Pulse Width	0.5		--	mSec	
T_{pd}	Propagation Delay		0.5		mSec	Input to Output, Note 1
--	Repeatability/Jitter (+/-)		0.5 1		mSec %	Notes 1, 2
T_{adb}	Adaptive Debounce		8		mSec	α Mode Only
--	Timing Accuracy (+/-)		1 1		mSec %	Note 2
tr/ff	Output On/Off (rise/fall) time		50	100	nSec	Output FETs Switching Time (120mA resistive load, $C_L=0pf$)

Notes:

- Does not apply to α Mode because input signal is debounced for 7mS.
- Whichever is greater.

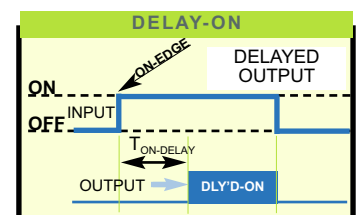
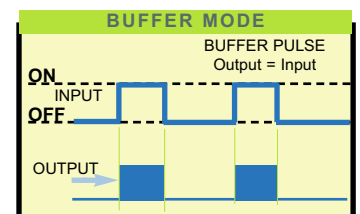
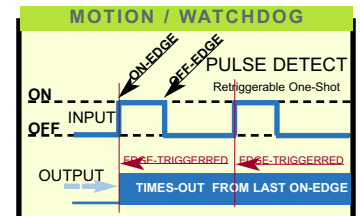
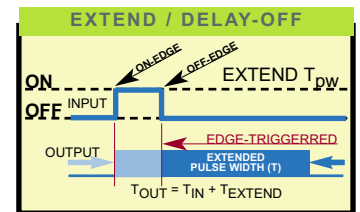
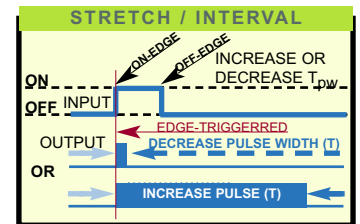

SPECIAL I/O FUNCTIONS	
A - Automatically detects Input Polarity. ● PNP / ● NPN Input/Output Optimization [I/O ²]	● PNP input to ● PNP output. ● NPN input to ● NPN output.
X - Automatically detects and determines Input Polarity and produces 'complimentary output polarity.'	Converts ● PNP input to ● NPN output; converts ● NPN input to ● PNP output.
N - Forces Input detection and Output to ● NPN mode.	● NPN input to ● NPN output only.
P - Forces Input detection and Output to ● PNP mode.	● PNP input to ● PNP output only.
α - Automatically detects Input Polarity and <u>debounces</u> for about 8mS. ● PNP / ● NPN Input/Output Optimization [I/O ²]	For signals from mechanical relay and contacts or noisy signals. Signal must be present for 8mS. Adds >8mS delay to input detection.

PTM-300 Series™

Pulse Timing Module

*Absolute Maximum Ratings

Supply Voltage [Vop] (pins 2 to 7) +/- 32 VDC
 INPUT Voltage (pin 5 to 7) -1V to (Vop + 1V)
 OUTPUT Voltage (pin 3 to 7) 0v to Vop
 OUTPUT Current (pin 3) +/- 200 mA (Protected)
 Ambient Operating Temperature 0° to +50° C (PTM-300U)
 -40° to +85° C (PTM-300)

***NOTE:** STRESSES ABOVE THOSE LISTED UNDER ABSOLUTE MAXIMUM RATINGS MAY CAUSE PERMANENT DEVICE DAMAGE. OPERATION AT THESE RATINGS FOR EXTENDED PERIODS MAY AFFECT RELIABILITY. SEE ELECTRICAL SPECIFICATIONS FOR RECOMMENDED OPERATING PARAMETERS.

Part Numbering



Base Part No. **PTM-300U** -

USER CONFIGURABLE
w/LCD Display

Pulse Timing Module w/
User Interface (LCD Display
& Push-button selections).

[Blank] - NPN/PNP SSR Output
 -12V/5A - 5 Amp 12/15V Relay FORM A
 -24V/5A - 5 Amp 24V Relay FORM A
 -12V/C - 10VA 12/15V Reed RLY FORM C
 -24V/C - 10VA 24V Reed RLY FORM C

[Blank] - Auto Detecting Input
 -ISO - Opto-Isolated 10-30V
 -ISO5 - Opto Isolated 5V

[Blank] - 10-30VDC Operation
 -5V - 5VDC Operation

[Blank] - PB Timing Adjust
 -VR - Multi-turn Timing Adjustment

Dimensions

Dimensions are in inches, except where noted otherwise.

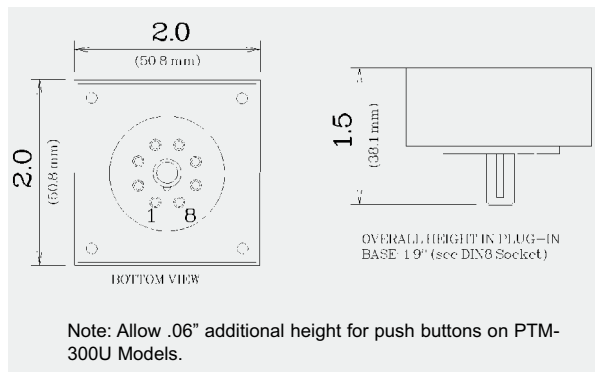

Example: PTM-300U-ISO-5A

PTM-300 Series Pulse Timing Module w/ User Configurable (LCD Display), 10-30V operation, Optically- Isolated 10-30VDC Input, 5 Amp Relay FORM 1A output. Non-Harsh Environment: 0° to +50° C Operating Temperature.

FACTORY CONFIGURED - AS ORDERED



Base Part No. **PTM-300** - Timing **TM** - Function **FM** - Time-out - Option(s) -

Pulse Timing Module
(Factory Configured)

[Blank] - NPN/PNP SSR Output
 -12V/5A - 5 Amp 12/15V Relay FORM A
 -24V/5A - 5 Amp 24V Relay FORM A
 -12V/C - 10VA 12/15V Reed RLY FORM C
 -24V/C - 10VA 24V Reed RLY FORM C

[Blank] - Auto Detecting Input
 -ISO - Opto-Isolated 10-30V
 -ISO5 - Opto Isolated 5V

[Blank] - 10-30VDC Operation
 -5V - 5VDC Operation

- 0 - Buffer
- 1 - Pulse Stretcher
- 2 - Interval Timer
- 3 - Pulse Extend
- 4 - Motion Detect
- 5 - Delay-ON-Make
- 6 - Delay-OFF

- 0 - Auto-Detect ● PNP/● NPN
- 1 - \bar{x} Output Polarity Inverted
- 2 - ● NPN Mode Only
- 3 - ● PNP Mode Only
- 4 - α Input 7mS Debounce

- MSxxx (specify xxx milliseconds) RANGE: 10mS to 999mS
- Txx.x (specify xx.x in seconds) RANGE: 1.0 Sec to 60.0 Sec
- VR - Multi-turn User Timing Adjustable

Example: PTM-300-TM1-FM0-MS031

PTM-300, 10-30V operation, Factory configured: Pulse stretcher, Auto-detect ● PNP/● NPN input, 31mS time-out. Standard ● PNP/● NPN 125mA solid-state output. Industrial Rated -40° to +85° C Industrial Operating Temperature.