

# ABB Arc Guard System™ TVOC

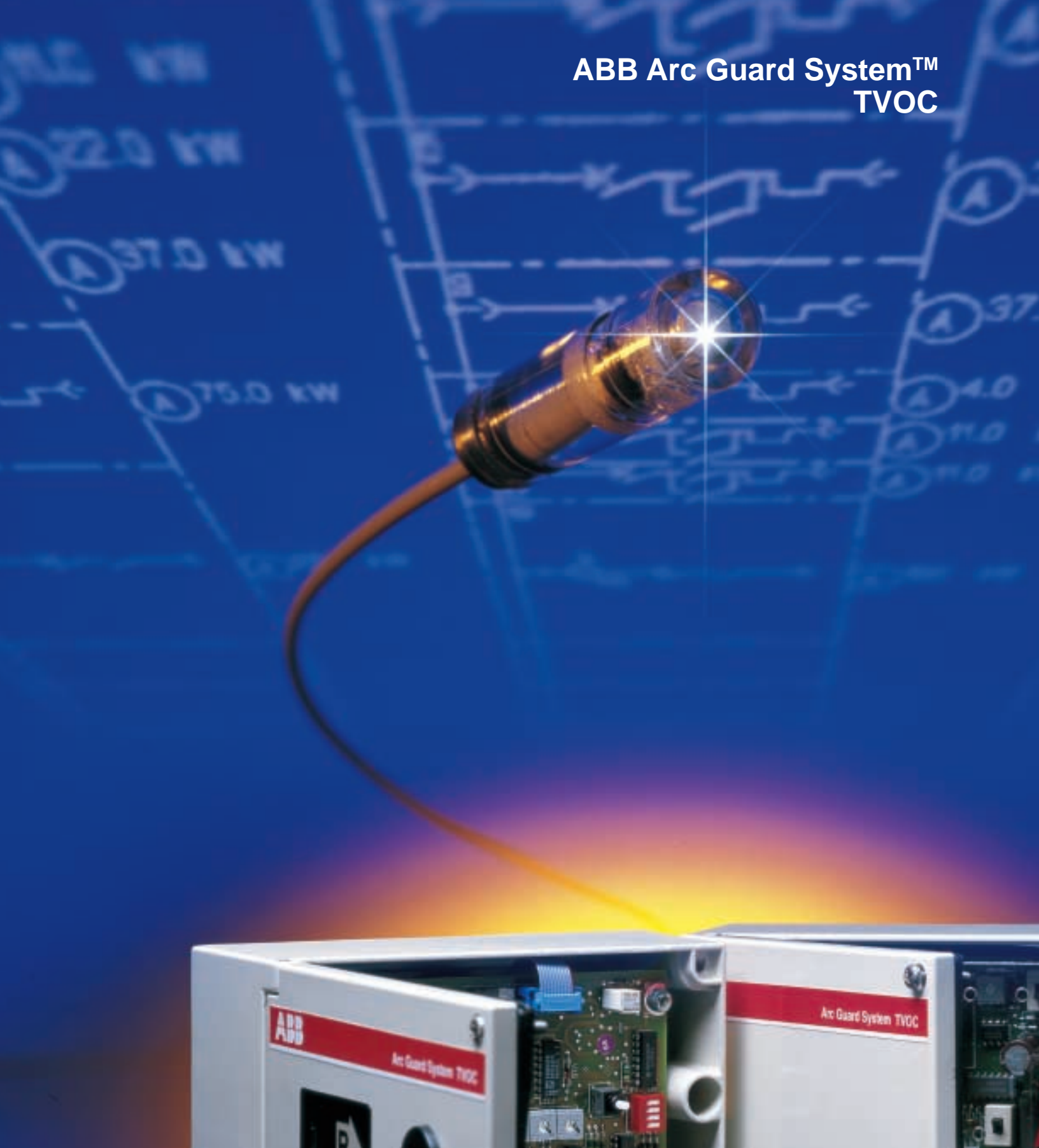

Low Voltage Products & Systems



# Accidents can occur whenever electrical energy is generated or distributed...



Short circuits in electrical installations can be a hazard. This is a recognized fact, and measures are normally taken to limit the consequences of a fault. However, most of the measures taken only partly eliminate the risk of a short circuit as they do not adequately cover arcing accidents.

## Short circuits involving an arc may occur for many different reasons:

### Human errors

Installers working under stress may forget or drop something on live parts. Simply using a meter set for amps instead of volts is enough to cause a serious arcing accident.

### Bad connections

A poor connection may cause generation of heat, which in the end leads to an arcing accident. The reason for this may, for instance, be wrong tightening torque being used on the terminals, a hostile environment, excessive vibrations, atmosphere, etc .

### Animals

Animals or vermin entering into electrical installations are very likely to cause short circuits with arcs.

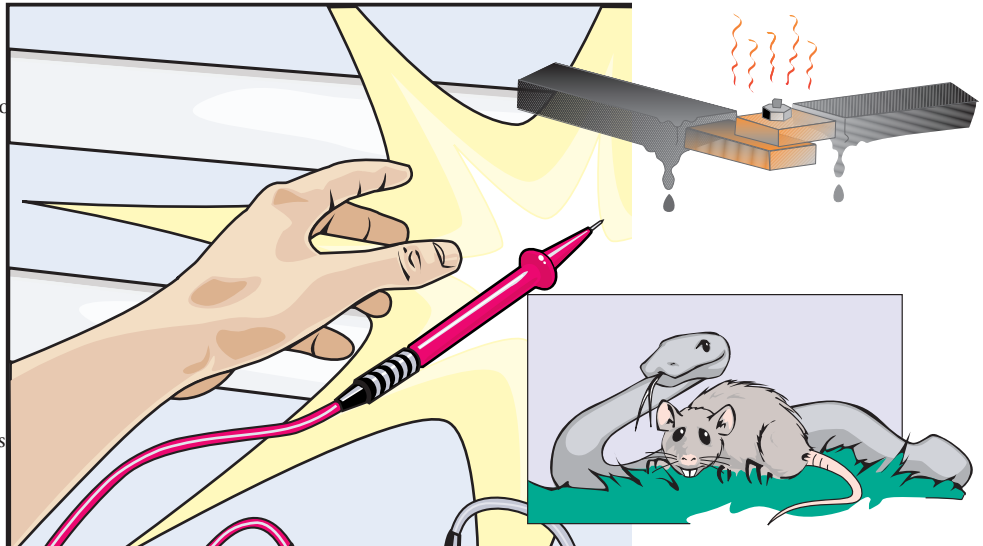

# Arcing accidents... it's only a matter of milliseconds

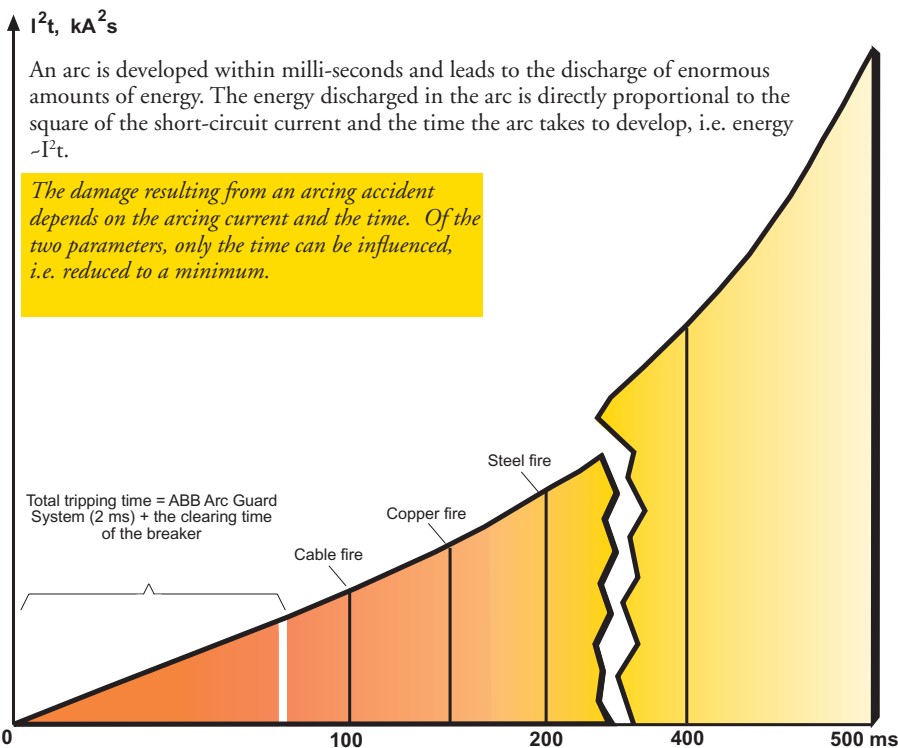

## Arc duration and resulting damage

- <100ms—ABB's Arc Guard System responds in conjunction with circuit breakers to limit personnel injury and equipment damage
- 100ms –Personnel and equipment are at risk
- >500ms—Catastrophic damages to equipment and personnel are likely to occur

## Serious consequences of arcing accidents

The arc leads to a rapid build-up of pressure and heat. The arc temperature has been determined to be about 20,000 °C, i.e. over three times the temperature of the sun's surface! The extreme heat of the arc leads to the burning of metals, which results in generation of toxic gases. Due to the vast amounts of energy re-leased in an arcing accident, the resulting damage is often extensive. This leads to considerable economic losses.

- Loss of production. Long downtimes are to be expected, due to the exten-sive damage often following an arcing accident.

If non-arc-proof switchgear is used, it may additionally lead to:

- Injuries due to pressure, heat or the generation of toxic gases.
- Damage to equipment and buildings

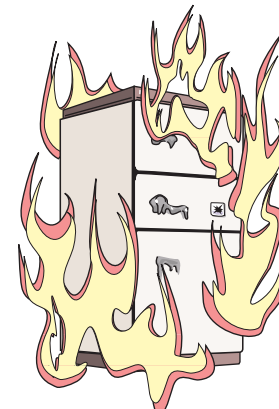
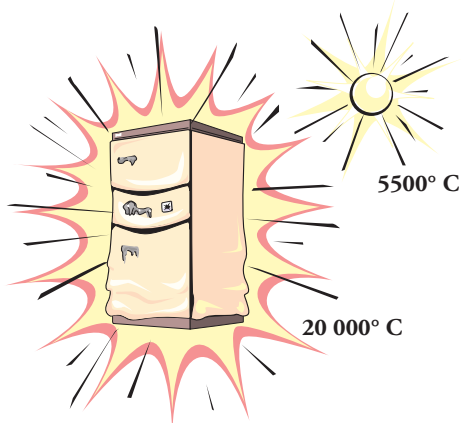

# Why normal protection is often not enough!

Normal short-circuit protection equipment has problems in detecting the arc fault before considerable damage has occurred. This is due to the fact that in an arc the resistance may be quite high, and consequently the current may not be very high, i.e. not high enough for the magnetic release of the breaker to trip.

The inability of breakers to eliminate the risk of arcing accidents is accentuated in the following two cases:

## Fig. 1

In order to achieve the required selectivity, the incoming breaker has been delayed by 150–200 ms. During the delay time an arc may cause major damage.

## Fig. 2

The incoming breaker is set at a high trip level in order to avoid nuisance tripping due to high inrush currents when energizing the transformer. The fault current upon the occurrence of an arc may be lower than the set level and the breaker then does not trip.

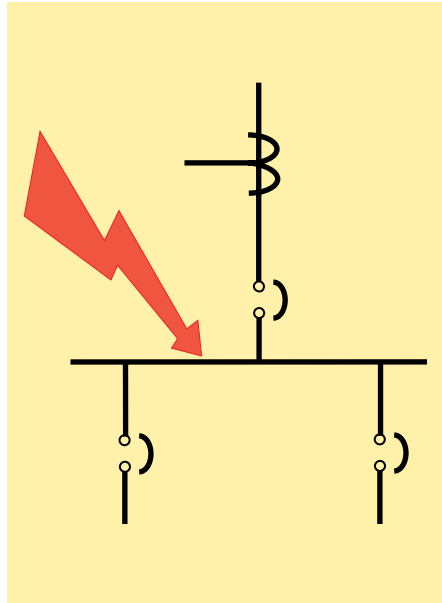

Fig. 1

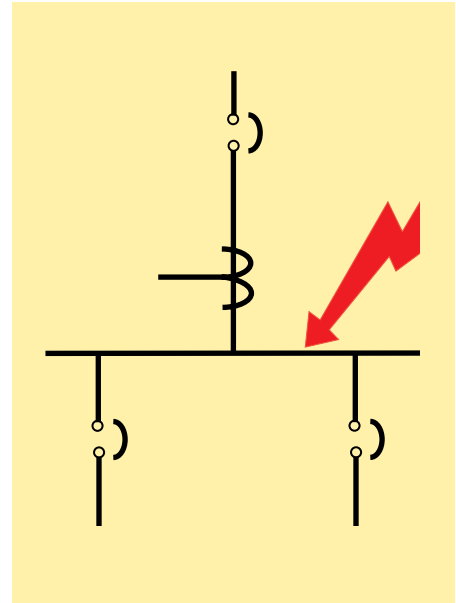

Fig. 2

## How to extinguish the arc before severe damage arises

The use of an ABB Arc Guard System will minimize the arc fault time.

The advantages are:

- Safety of personnel even when switchgear door is open.
- Reduced damage inside the cubicles.
- Reduced downtime.
- Reduced repair and reconstruction expenses



Low voltage switchgear during test



Damage caused to medium voltage switchgear by an arc fault



## The solution is the ABB Arc Guard System™ TVOC

**ABB has recognized the hazards of arcing accidents and has developed a system which significantly reduces the damage resulting from an arcing accident.**

Using the ABB Arc Guard System TVOC in combination with today's modern breakers, the total disconnection time can be reduced to less than 50 ms.

### **This is how it works....**

The purpose of the ABB Arc Guard System is to quickly disconnect the switchgear directly after an arcing fault.

The watchful eye of the Arc Monitor detects any large increase in light intensity. Upon detection of an arc, the Arc Monitor sends a signal directly to the tripping mechanism of the breaker, thus omitting any delays caused by relay protection or set delays due to selectivity.

### **...by using the speed of light**

ABB Arc Guard System uses the speed of light. The Arc Guard System delivers the trip signal in approximately 1 to 2 milliseconds. The actual disconnection time depends on the type of circuit-breaker used, but the entire process normally takes less than 50 milliseconds

### **Fiber optics ensure no interference...**

In the environment of switchgear and other

electrical installations, elevated electromagnetic fields, especially in the event of a fault, are common. The ABB Arc Guard System is designed to withstand the severest electromagnetic disturbances. Fiber optics, which are totally insensitive to electromagnetic fields, are used both for the detectors and the communication between the optical detector and other units of the ABB Arc Guard System. The ABB Arc Guard System is immediately activated when the power is turned on and will react to existing arc faults. This ensures the protection of installations such as substations, which are not at all times under power.

### **...and easy installation in new and old switchgear**

The ABB Arc Guard System is easily installed in all types of switchgear. The fiber optic cables and detectors can be installed in the switchgear without any concern about the power or control cabling since they are nonconductive and not sensitive to electrical or magnetic fields. The placing of the detectors is not crucial due to the wide angle lens. The detectors are provided in fixed lengths and all are adjusted to ensure the same sensitivity to light.



Detector

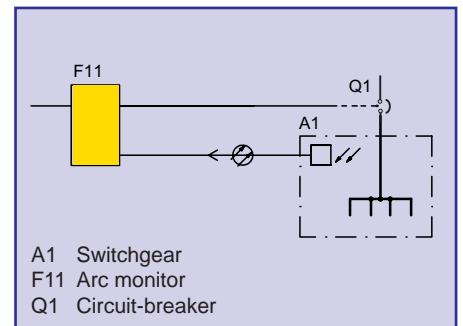

# It must be possible to discover arcs wherever they occur in the switchgear

## With ABB Arc Guard System, the whole switchgear assembly can be monitored

One of the key features of the Arc Guard System is the design of the detectors, which have a detection range of almost 360°. As many as nine detectors can be connected to each arc monitor. Several arc monitors can be connected together.

In principle, one detector should be placed in each closed unit or cell. The number of detectors required to ensure satisfactory protection depends on how the switchgear is arranged with respect to internal screening, etc.

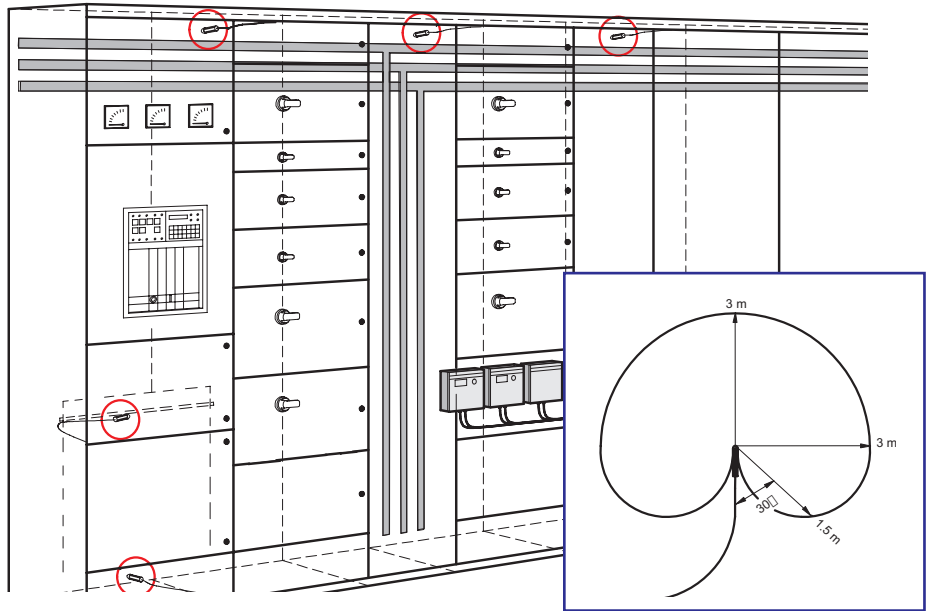

Example showing the position of detectors in a circuit-breaker cubicle and in a horizontal busbar system.

Polar diagram of detector sensitivity

# Current sensing unit to prevent nuisance tripping

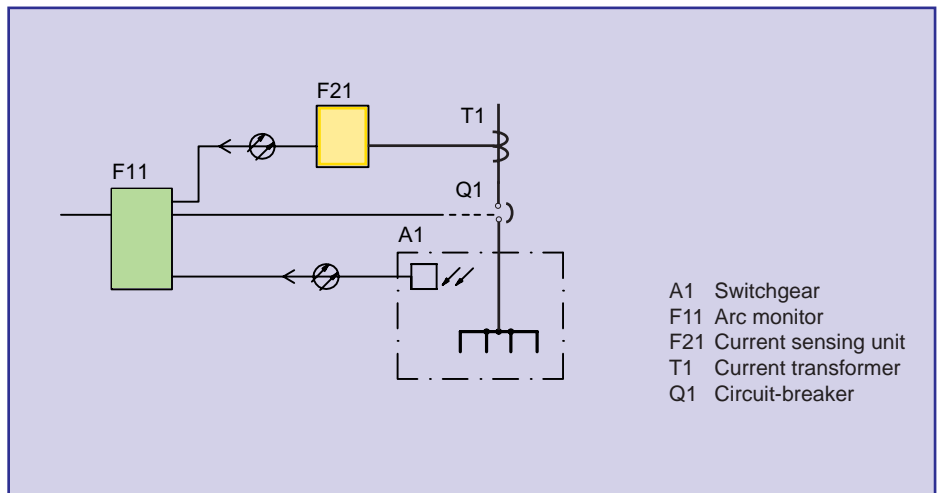

The detectors can also react to other forms of intense light such as camera flashes, direct sunlight or welding.

In order to avoid power loss due to nuisance tripping a current sensing unit can be installed. When combining the arc monitor with a current sensing unit the trip or release level can be adjusted just above the normal operation current of the installation. A current-dependent condition is introduced, which prevents tripping due to irrelevant light sources.

# ABB Arc Guard System TVOC – an investment in safety

## Light sensors anticipate destructive arcs

—A success story from Boston Edison Co.

Speed is essential to minimize the destructive effects and personal hazards when a short circuit occurs in electrical equipment. But in many cases, by the time the current has risen to a level high enough to operate the protective relay and the circuit breaker has opened, destructive arcing and short-circuit forces may have destroyed switchgear and, in extreme cases, injured or killed operators working nearby.

A new type of protective device has been developed that uses light sensors to detect arcing at its earliest stages and initiate the trip before normal relay operation. The system, known as Arc Guard™, is manufactured by ABB Control Inc., Wichita Falls, TX. The system is particularly applicable to enclosed switchgear with minimal bus spacing where unstrained arcing can generate high internal pressures that burst enclosures and injure personnel with flying components.

Boston Edison Co. (BECO) successfully tested the Arc Guard to protect the part of Boston's underground network system that operate at 277/480 V. The system has 490 network transformers operating at this voltage, which has been shown to be high enough to sustain an arcing fault.

There is an unprotected zone in the system located on the transformer secondary between the coils and the fuses on the network protector. Arcing faults starting in this area can continue without detection by the normal protection system. A recent series of tests at BECO showed that light sensors could detect an arc and send a signal to an upstream device in time to prevent significant damage to the vault equipment and possible injury.

In the test system, four light detectors were set up at distances ranging from 7 to 102 in. from the unprotected bus. A resistive load on the transformer was adjusted to draw a stabilized current of about 300 amp. An arcing condition was then deliberately created by shorting the 0.59-in. air gap between copper bus with a short piece of fuse wire on a hot stick.

When this test was performed without the Arc Guard in operation, the fault current was 43.0 kA and the total tripping time of the upstream device was 141 milliseconds.

Several tests were then conducted using different combinations of light sensors. While the fault current in each test remained approximately the same, the total tripping time, and hence the fault energy, was reduced by about 75%. In one test, a dirty piece of Plexiglas was placed between the light detector and the arc. No significant increase in the tripping time was noticed. In this case the device saw the arc and generated a trip signal in 1.3 milliseconds. Total time to clear the fault was 42.7 milliseconds. Following the successful tests it is probable that the Arc Guard system will be placed in each circuit protector to monitor faults on all three phases of the unprotected section of bus. Another possible location for the fault detector is the point where the bus leaves the vault and is enclosed by sheet metal.

*Article published in Electrical World, October 1994, Vol.208*

## Guideline specifications

### Switchgear protection

A switchgear protection system shall be included based on the ABB Arc Guard System or equivalent, operating in conjunction with an Arc Monitor. At least one detector shall be included for each compartment of metal clad or metal enclosed switchgear.

In the metal clad switchgear, optical detectors will be located in each vertical section including detectors in the main horizontal bus compartments, in each circuit breaker compartment, and in the rear compartments where bus connections to outgoing cable and lightning arrestors are to be monitored. In low voltage switchgear, detectors will be located to monitor the main bus, breakers, and connections to outgoing cables. All detectors shall be arranged to give maximum coverage to the compartment in which they are located. Additional detectors shall be added as required to obtain complete coverage. Tripping shall be arranged so that all circuits connected to a faulty section of a main bus are tripped.

To cover the condition when feeder circuits are acting as incoming or outgoing circuits, the current measuring input for each section of the main bus shall be operated from current transformers on all feeder circuits.

The Arc Guard System protection scheme offered shall include all necessary interconnections within the basic switchgear lineup.

## Major United States Arc Guard System users

Air Products, California  
American Steel & Wire, Ohio  
Amtrak, New Jersey  
BG& E – Bechtel Engineering, Maryland  
Bethlehem Steel, Indiana  
Bonneville Power, Oregon  
Boston Edison Company, Massachusetts  
Disney Company, Florida  
Fibro-Matrix Engineering, Texas  
Fuji Electronic Corporation, New Jersey  
Georgia Pacific, Oregon, Virginia, West Virginia  
Geneva Steel, Utah  
Gillette, Massachusetts  
Houston Light & Power, Texas  
James River Company, Maine  
Kvaerner Pulping, Wisconsin  
Lawrence Berkeley Laboratory, California  
Malden Mills, Massachusetts  
New York City Transit Authority, New York  
Nippondenso Tennessee, Tennessee  
New Mexico State University, New Mexico  
Potomac Electric, Pennsylvania  
Shell Oil, Texas  
Special Metals, Texas  
Specialty Minerals, Inc., Pennsylvania  
UC Berkeley, California  
University of Maryland, Maryland  
West Penn Power, Pennsylvania

## Application opportunities

- Suitable for installation in new or existing high, medium and low voltage switchgear systems
- Installs in non-segregated phase bus duct
- Equipped with auxiliary circuit for external indication
- Backup to protective relays in arcing faults
- Metal enclosed capacitor banks
- Transformer load tap changer panels
- Wherever unwanted arcs are a problem

## Approvals

- Underwriters Laboratories  
File #E155370
- Factory Mutual system  
Reference FMRC J.I. 1B1A4.AF
- Lloyd's Register of Shipping  
Cert. # 97/00189
- Det Norske Veritas  
Cert. # A-6702
- Germanischer Lloyd  
Cert. #99.342-97
- CE Marked
- Earthquake tested according to ANSI/IEEE  
C37.98 - 1987



**ABB is the world leader in Arc Guard Systems  
and has more than 30 years of experience  
in arc accident protection**



Low Voltage Products & Systems

ABB Inc.  
1206 Hatton Road  
Wichita Falls, TX 76302  
Tel. 888-385-1221  
940-397-7000  
Fax 940-397-7085  
Web [www.abb-control.com](http://www.abb-control.com)

AC 1201  
April, 1998